

MAB 103B-24

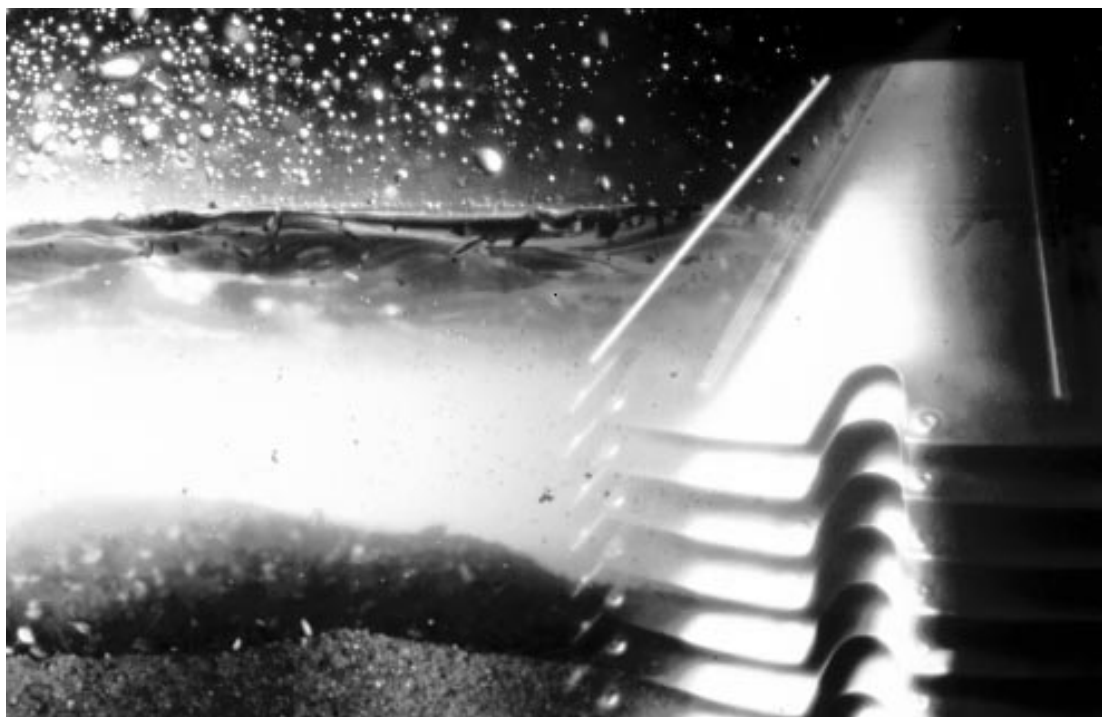

Separator Manual

Product No.
Book No.

881145-09-01
1270118-02 V4

Alfa Laval Separation AB
Separator Manuals, dept. SKL
S-147 80 Tumba, Sweden

Telephone: +46 8 53 06 50 00
Telefax: +46 8 53 06 50 29

Printed in Sweden, 97-08

© **Alfa Laval Separation AB 1997**

This publication or any part thereof may not be reproduced or transmitted by any process or means without prior written permission of Alfa Laval Separation AB.

Contents

1	Read this first	7
2	Safety Instructions	9
3	Separator Basics	15
3.1	Basic principles of separation	16
3.2	Overview	19
3.3	Separating function	20
3.4	Mechanical function	23
3.5	Definitions	27
4	Operating Instructions	29
4.1	Operating routine	30
4.2	Cleaning the bowl	37
5	Service Instructions	43
5.1	Periodic Maintenance	44
5.2	Maintenance Logs	46
5.3	MS - Check points	52
5.4	Cleaning	66
5.5	When changing oil	70
5.6	Common maintenance directions	72
5.7	Lifting instructions	76

6	Dismantling/Assembly	77
6.1	General	78
6.2	Dismantling	79
6.3	Assembly	89
6.4	Feed and discharge pumps	97
6.5	Oil filling	102
6.6	Brake	103
6.7	Frame feet	104
7	Trouble-tracing	105
7.1	Trouble tracing procedure	106
7.2	MAB mechanical function	106
7.3	Purification faults	112
7.4	Clarification faults	114
8	Technical Reference	115
8.1	Technical data	116
8.2	Basic size drawing	122
8.3	Connection list	124
8.4	Basic size drawing, for heater	125
8.5	Connection list, for heater	127
8.6	Interface description	128
8.7	Lubricants	131
8.8	Drawings	139
8.9	Storage and installation	151
	Index	161

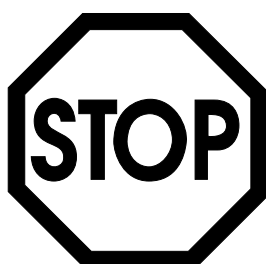

Study instruction manuals and observe the warnings before installation, operation, service and maintenance.

Not following the instructions can result in serious accidents.

In order to make the information clear only foreseeable conditions have been considered. No warnings are given, therefore, for situations arising from the unintended usage of the machine and its tools.



1 *Read this first*

This manual is designed for operators and service engineers working with the Alfa Laval separator MAB 103B-24.

For information concerning the function of the separator, see “3 Separator Basics” on page 15, and “4 Operating Instructions” on page 29.

If the separator has been delivered and installed by Alfa Laval as part of a processing system, this manual is a part of the System Manual. In this case, study carefully all the instructions in the System Manual.

In addition to this Separator Manual a Spare Parts Catalogue, SPC is supplied.



Separator Manual and Spare Parts Catalogue

50068011

This Separator Manual consists of:

Safety Instructions

Pay special attention to the safety instructions for the separator. Not following the safety instructions can cause accidents resulting in damage to equipment and serious injury to personnel.

Separator Basics

Read this chapter if you are not familiar with this type of separator.

Operating Instructions

This chapter contains operating instructions for the separator only.

Service Instructions

This chapter gives instructions for daily checks, cleaning, oil changes, servicing and check points.

Dismantling / Assembly

This chapter contains step-by-step instructions for dismantling and assembly of the separator for service and repair.

Trouble-tracing

Refer to this chapter if the separator functions abnormally.

If the separator has been installed as part of a processing system always refer to the Trouble-tracing part of the System Manual first.

Technical Reference

This chapter contains technical data concerning the separator and drawings.

Installation

General information on installation planning.

Lifting instruction.

Index

This chapter contains an alphabetical list of subjects, with page references.

2 Safety Instructions



The centrifugal separator includes parts that rotate at high speed. This means that:

- Kinetic energy is high
- Great forces are generated
- Stopping time is long

Manufacturing tolerances are extremely fine. Rotating parts are carefully balanced to reduce undesired vibrations that can cause a breakdown. Material properties have been considered carefully during design to withstand stress and fatigue.

The separator is designed and supplied for a specific separation duty (type of liquid, rotational speed, temperature, density etc.) and must not be used for any other purpose.

Incorrect operation and maintenance can result in unbalance due to build-up of sediment, reduction of material strength, etc., that subsequently could lead to serious damage and/or injury.

The following basic safety instructions therefore apply:

- **Use the separator only for the purpose and parameter range specified by Alfa Laval.**
- **Strictly follow the instructions for installation, operation and maintenance.**
- **Ensure that personnel are competent and have sufficient knowledge of maintenance and operation, especially concerning emergency stopping procedures.**
- **Use only Alfa Laval genuine spare parts and the special tools supplied.**

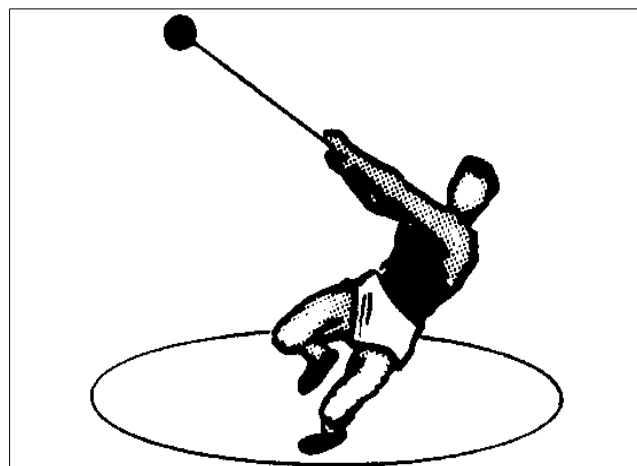



DANGER



Disintegration hazards

- Use the separator only for the purpose and parameter range specified by Alfa Laval.
- If excessive vibration occurs, **stop** separator and **keep bowl filled** with liquid during rundown.
- When power cables are connected, always check direction of motor rotation. If incorrect, vital rotating parts could unscrew.
- Check that the gear ratio is correct for power frequency used. If incorrect, subsequent overspeed may result in a serious break down.
- Welding or heating of parts that rotate can seriously affect material strength.
- Wear on the large lock ring thread must not exceed safety limit. ϕ -mark on lock ring must not pass opposite ϕ -mark by more than specified distance.
- Inspect regularly for **corrosion** and **erosion** damage. Inspect frequently if process liquid is corrosive or erosive.

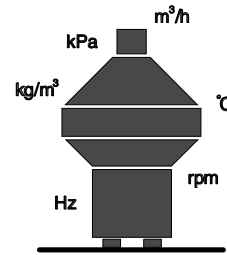

S00051311

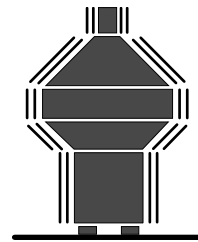

S00055611



DANGER

Entrapment hazards

- Make sure that rotating parts have come to a **complete standstill** before starting **any** dismantling work.
- To avoid accidental start, switch off and lock power supply before starting **any** dismantling work.
- Assemble the machine **completely** before start. **All** covers and guards must be in place.

Electrical hazards

- Follow local regulations for electrical installation and earthing (grounding).

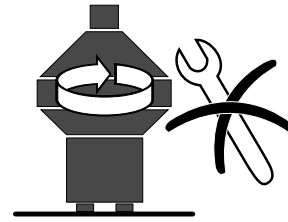

S0051111

S0051011



WARNING

Crush hazards

- Use correct lifting tools and follow lifting instructions.
- Do **not** work under a hanging load.

Noise hazards

- Use ear protection in noisy environments.

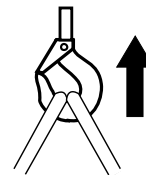

S0051711

S0051611



CAUTION

Burn hazards

- Lubrication oil and various machine surfaces can be hot and cause burns.

Cut hazards

- Sharp edges on separator discs and lock ring threads can cause cuts.



S0055411



S0054311



Warning signs in the text

Pay attention to the safety instructions in this manual. Below are definitions of the three grades of warning signs used in the text where there is a risk for injury to personnel.



DANGER

Type of hazard

This type of safety instruction indicates a situation which, if not avoided, could result in **fatal injury** or fatal damage to health.



WARNING

Type of hazard

This type of safety instruction indicates a situation which, if not avoided, could result in **disabling injury** or disabling damage to health.



CAUTION

Type of hazard

This type of safety instruction indicates a situation which, if not avoided, could result in **light injury** or light damage to health.

NOTE

This type of instruction indicates a situation which, if not avoided, could result in damage to the equipment.



3 *Separator Basics*

Contents

3.1 Basic principles of separation	16
3.1.1 Factors influencing the separation result	17
3.2 Overview	19
3.3 Separating function	20
3.3.1 Purifier bowl	20
3.3.2 Position of interface - gravity disc	21
3.3.3 Clarifier bowl	22
3.4 Mechanical function	23
3.4.1 Inlet and outlet	23
3.4.2 Mechanical power transmission	24
3.4.3 Brake	25
3.4.4 Inlet and outlet pump	25
3.4.5 Sensors and indicators	26
3.5 Definitions	27

3.1 Basic principles of separation

The purpose of separation can be:

- to free a liquid of solid particles,
- to separate two mutually insoluble liquids with different densities while removing any solids presents at the same time,
- to separate and concentrate solid particles from a liquid.

Separation by gravity

A liquid mixture in a stationary bowl will clear slowly as the heavy particles in the liquid mixture sink to the bottom under the influence of gravity.

A lighter liquid rises while a heavier liquid and solids sink.

Continuous separation and sedimentation can be achieved in a settling tank having outlets arranged according to the difference in density of the liquids.

Heavier particles in the liquid mixture will settle and form a sediment layer on the tank bottom

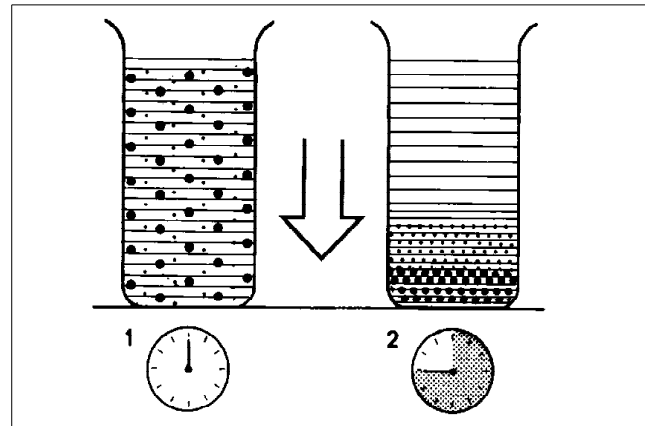

Sedimentation by gravity

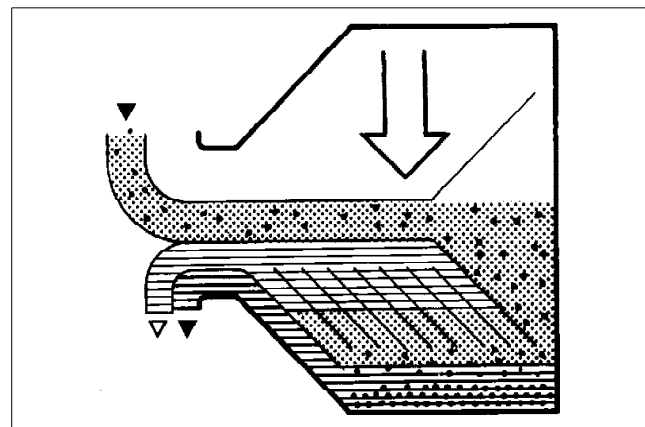

Sedimentation in a settling tank, with outlets making it possible to separate the lighter liquid parts from the heavier

Centrifugal separation

In a rapidly rotating bowl, the force of gravity is replaced by centrifugal force, which can be thousands of times greater.

Separation and sedimentation is continuous and happens very quickly.

The centrifugal force in the separator bowl can achieve in a few seconds what takes many hours in a tank under influence of gravity.

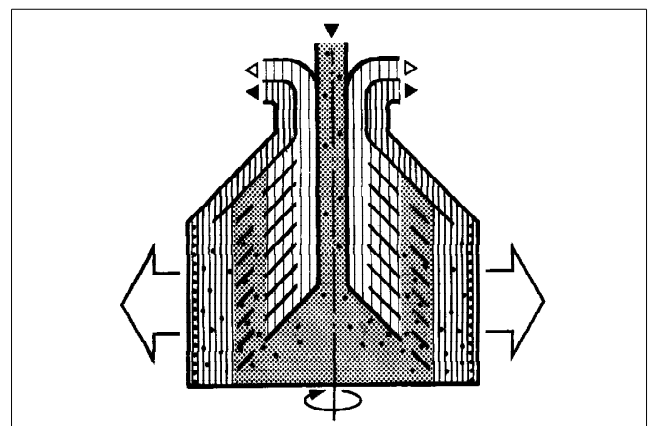

The centrifugal solution

3.1.1 Factors influencing the separation result

Separating temperature

For some types of process liquids (e.g. mineral oils) a high separating temperature will normally increase the separation capacity. The temperature influences oil viscosity and density and should be kept constant throughout the separation.

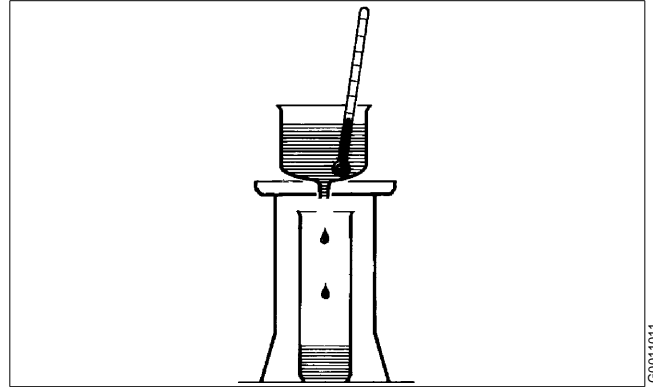

High viscosity (with low temperature)

Viscosity

Low viscosity facilitates separation. Viscosity can be reduced by heating.

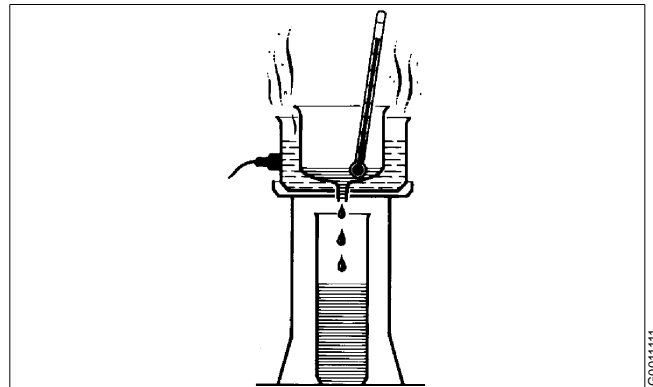

Low viscosity (with high temperature)

Density difference (specific gravity ratio)

The greater the density difference between the two liquids, the easier the separation. The density difference can be increased by heating.

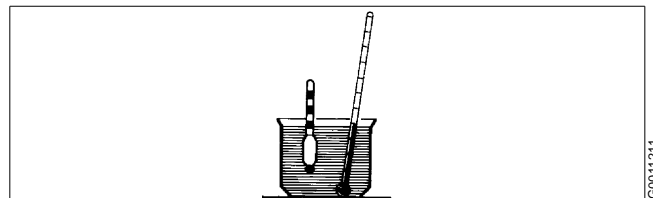

High density (with low temperature)

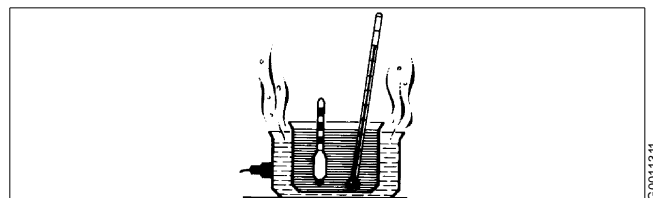

Low density (with high temperature)

Phase proportions

An increased quantity of water in a oil will influence the separating result through the optimum transporting capacity of the disc stack. An increased water content in the oil can be compensated by reducing the throughput in order to restore the optimum separating efficiency.

The throughput

The throughput sets the time allowed for the separation of water and sediment from the oil. A better separation result can often be achieved by reducing the throughput, i.e. by increasing the settling time.

Sludge space - sludge content

Sediment will accumulate on the inside periphery of the bowl. When the sludge space is filled up the flow inside the bowl is influenced by the sediment and thereby reducing the separating efficiency. In such cases the time between cleaning should be reduced to suit these conditions.

Disc stack

A neglected disc stack containing deformed discs or discs coated with deposits will impair the separating result.

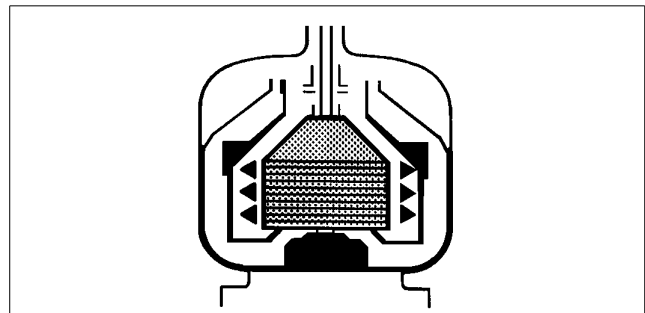

Sludge accumulation

G0601211

3.2 Overview

The separator comprises a processing part and a driving part. It is driven by an electric motor (6).

Mechanically, the separator machine frame is composed of a bottom part, a top part and a collecting cover. The motor is flanged to the frame as shown in the illustration. The frame feet have vibration damping.

The bottom part of the separator contains the horizontal driving device (1), driving shaft with couplings, a worm gear and a vertical spindle.

The bottom part also contains an oil bath for the worm gear, a brake and a revolution counter, indicating speed.

A pump (3) is attached to the driving spindle and located on the side of the bottom part. This pump has dual function. It is the feed inlet pump and the clean oil discharge pump.

The frame top part and the collecting cover contain the processing parts of the separator, the inlet and outlets and piping.

The liquid is cleaned in the separator bowl (4). This is fitted on the upper part of the vertical spindle and rotates at high speed inside the space formed by the frame top part and collecting cover.

The main inlets and outlets are shown with connection numbers in the illustration. These numbers correspond with the numbers used in the connection list and the basic size drawing which can be found in chapter "8 Technical Reference" on page 115.

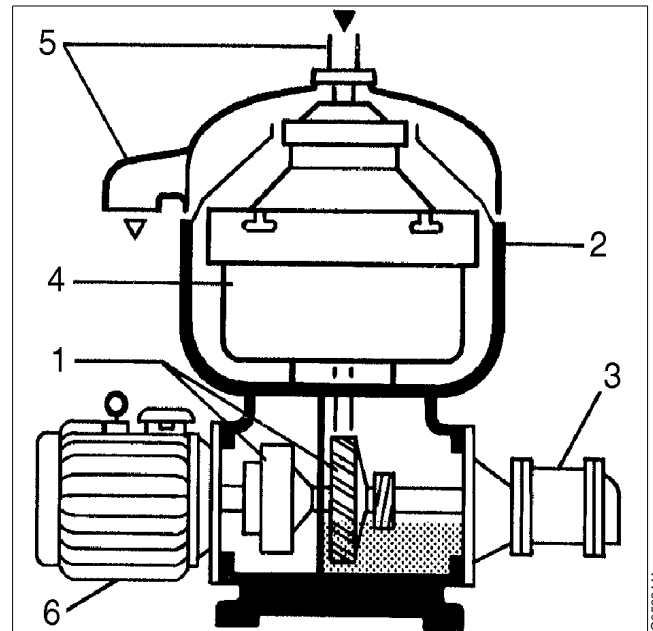

1. Horizontal driving device, friction coupling and worm gear
2. Collecting cover.
3. Inlet and outlet gear pump
4. Separator bowl
5. Inlet / outlet
6. Electric motor

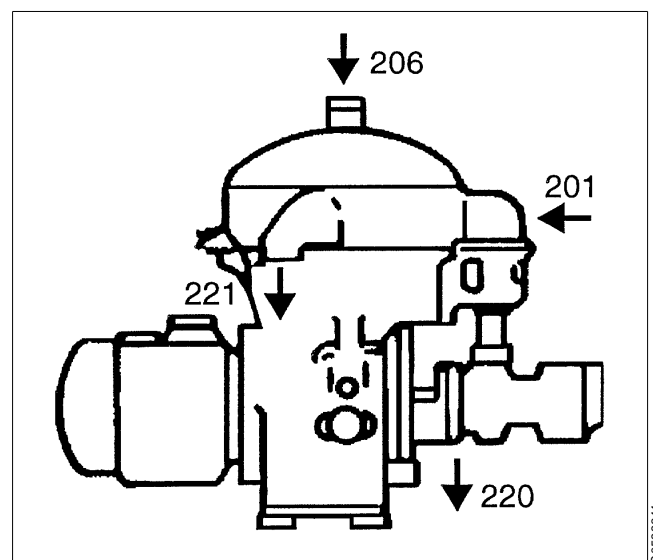

Inlet and outlet connections

3.3 Separating function

Unseparated oil is fed into the bowl through the inlet pipe and is pumped via the distributor towards the periphery of the bowl.

When the oil reaches holes of the distributor, it will rise through the channels formed by the disc stack where it is evenly distributed.

The oil is continuously cleaned as it flows towards the center of the bowl. When the cleaned oil leaves the disc stack it rises upwards, flows over the gravity disc and leaves the bowl through outlet (220). Separated water, sludge and solid particles are forced towards the periphery of the bowl and collected in the sludge space.

The space between bowl hood and top disc are normally filled with water.

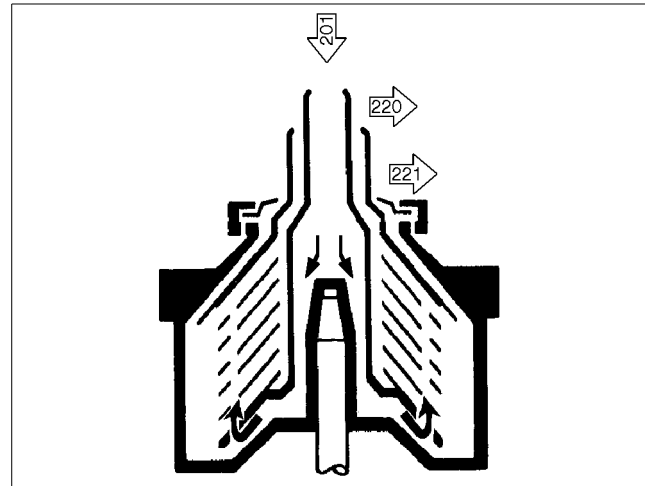

Process flow through separator bowl

3.3.1 Purifier bowl

The illustration shows characteristic parts of the purifier bowl:

1. Top disc with neck
2. The gravity disc, which should be chosen according to directions in chapter "4.1.2 Selection of gravity disc" on page 30.

This bowl has two liquid outlets. The process liquid flows through the distributor to the interspaces between the bowl discs, where the liquid phases are separated from each other by action of the centrifugal force. The heavy phase and any solids move along the underside of the bowl discs towards the periphery of the bowl, where the solids settle on the bowl wall.

The heavy phase flows along the upper side of the top disc towards the neck of the bowl hood and leaves the bowl via the gravity disc the outer way.

The light phase flows along the upper side of the bowl discs towards the bowl centre and leaves the bowl via the hole in the top disc neck the inner way.

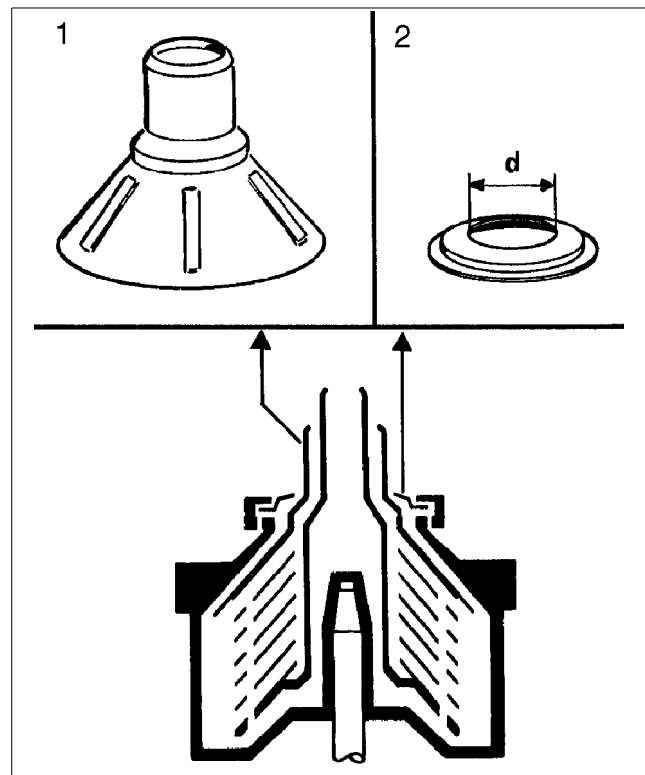

Purifier bowl

3.3.2 Position of interface - gravity disc

In a purifier bowl the position of the interface should be located between the disc stack edge and the outer edge of the top disc.

The position of the interface is adjusted by altering the pressure balance of the liquid phases oil and water inside the separator. That is done by exchanging the gravity disc. For this purpose a number of gravity discs with various hole diameters is delivered with the machine.

The gravity disc is located inside the bowl hood. A gravity disc with a larger hole will move the interface towards the bowl periphery, whereas a disc with a smaller hole will place it closer to the bowl centre.

Selection of gravity disc

For selection of gravity disc, see nomogram in chapter "8.1.1 Gravity disc nomogram" on page 120.

When selecting a gravity disc the general rule is to use the disc having the largest possible hole without causing a break of the water seal.

The heavier or more viscous the light phase and the larger the liquid feed the smaller the diameter should be.

When the heavy phase (water) is wanted more free from the light one (oil), the interface should be placed nearer the bowl centre, however not inside the outer edge of the discs (the gravity disc is too small), as this would prevent the liquid flow.

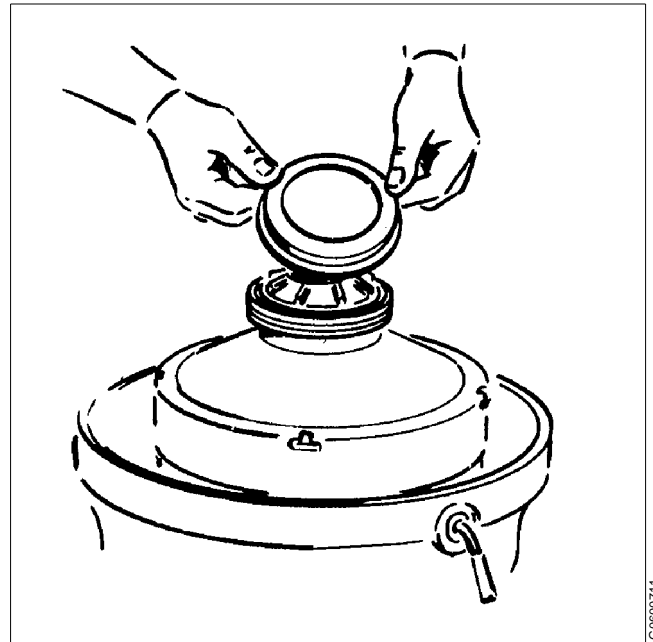

Gravity disc

G0600711

3.3.3 Clarifier bowl

The illustration shows characteristic parts of the clarifier bowl:

1. Discharge collar
2. Top disc without neck

This bowl has one liquid outlet. The process liquid flows through the distributor to the interspaces between the bowl discs. Through the action of the centrifugal force the heavy particles move along the underside of the discs towards the bowl periphery, where they settle on the bowl wall. The liquid proceeds towards the bowl centre and discharges through the bowl hood.

The separation is influenced by changes in the viscosity (rise in separating temperature) or in the throughput.

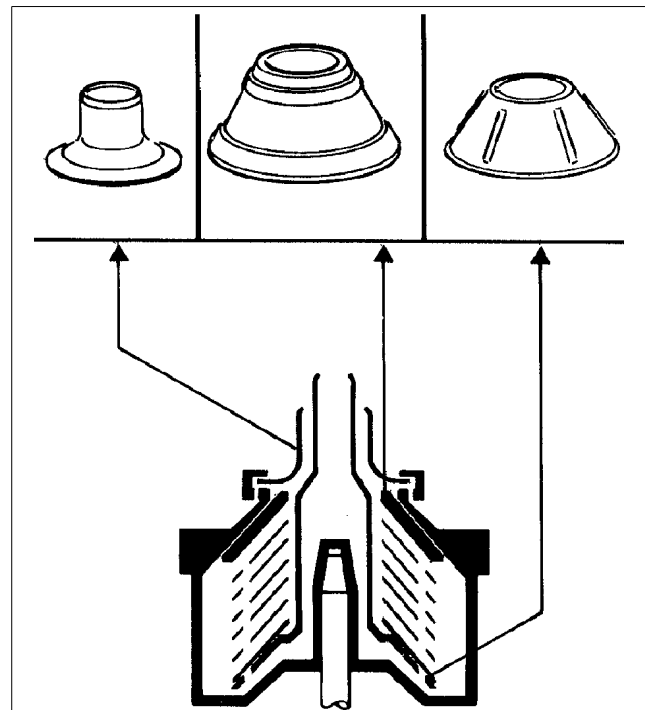

Clarifier bowl

G0589111

3.4 Mechanical function

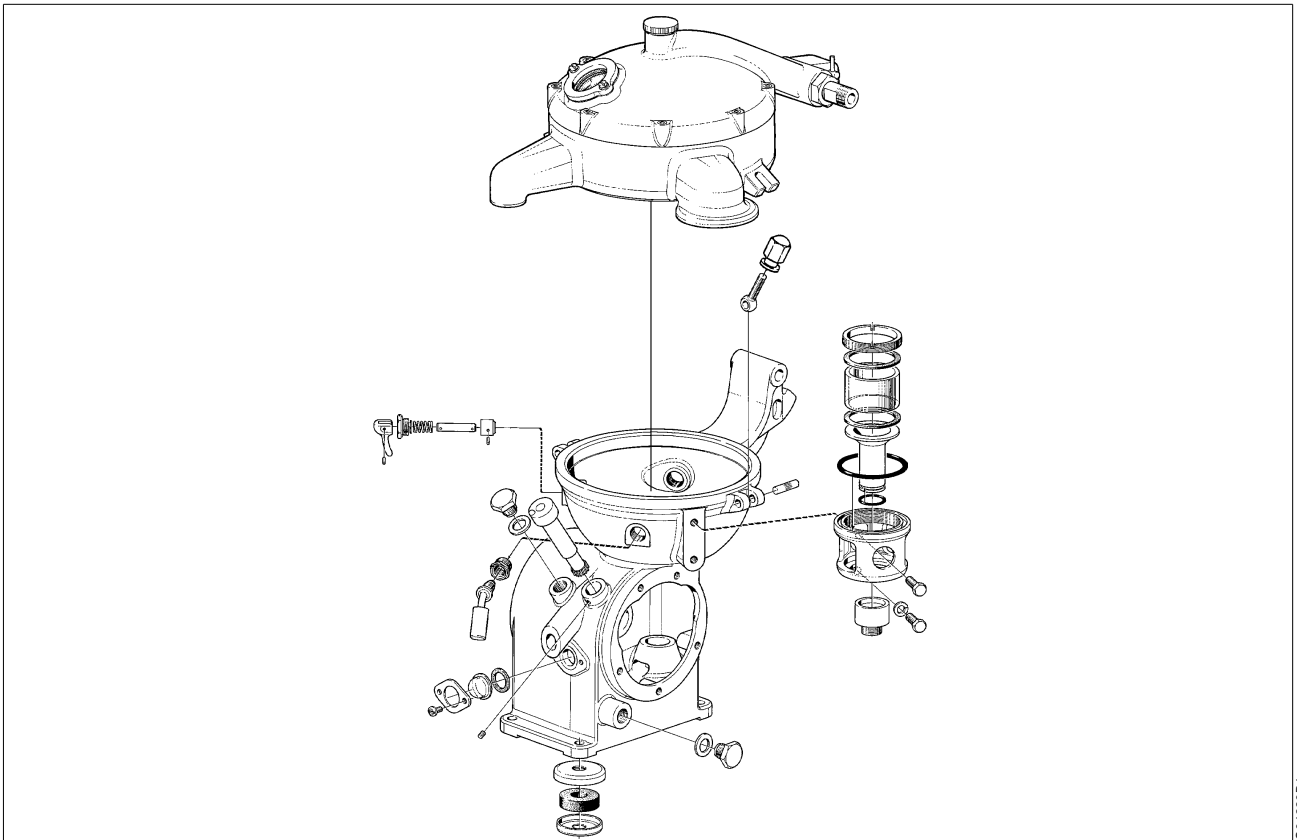

Exploded view

3.4.1 Inlet and outlet

The inlet and outlets consists of the following parts:

- The inlet (201).
- The inlet for water seal (206).
- The outlet for clean oil (220) from pump.
- The outlet for water (221).

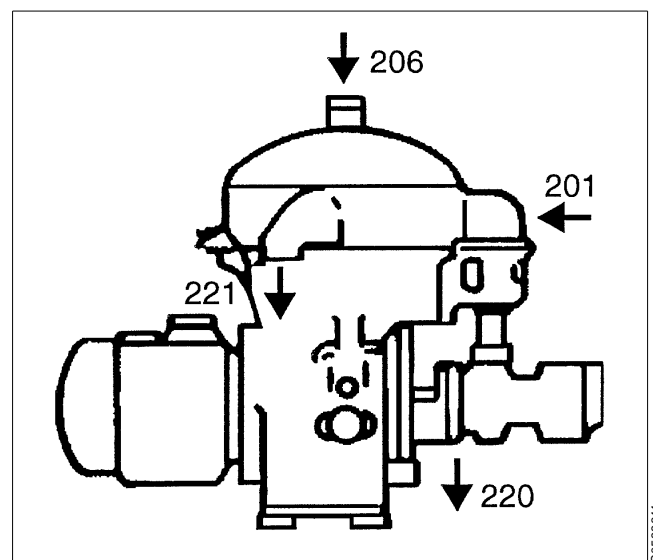

3.4.2 Mechanical power transmission

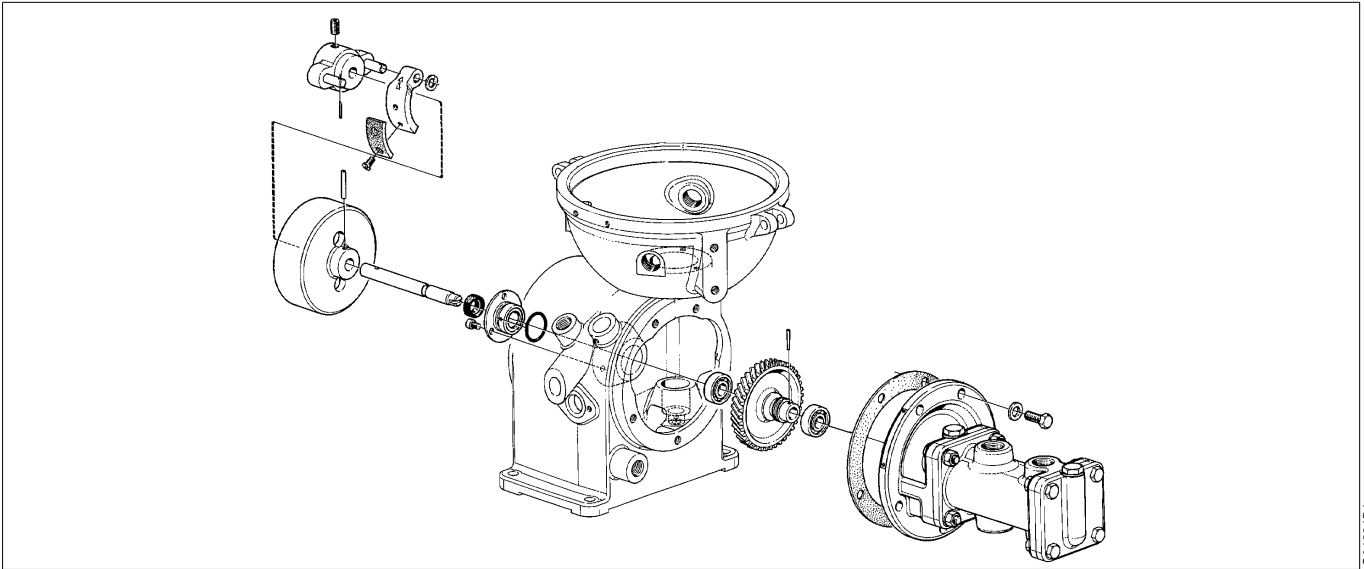

C01221B1

Horizontal drive

The main parts of the power transmission between motor and bowl are illustrated in the figure.

The friction coupling ensures a gentle start and acceleration and at the same time prevents overloading of the worm gear and motor.

The worm gear has a ratio which increase the bowl speed several times compared with the motor speed. For correct ratio see chapter "8 Technical Reference" on page 115.

To reduce bearing wear and the transmission of bowl vibrations to the frame and foundation, the top bearing of the bowl spindle is mounted in a spring casing.

The worm wheel runs in a lubricating oil bath. The bearings on the spindle and the worm wheel shaft are lubricated by the oil splash produced by the rotating worm wheel.

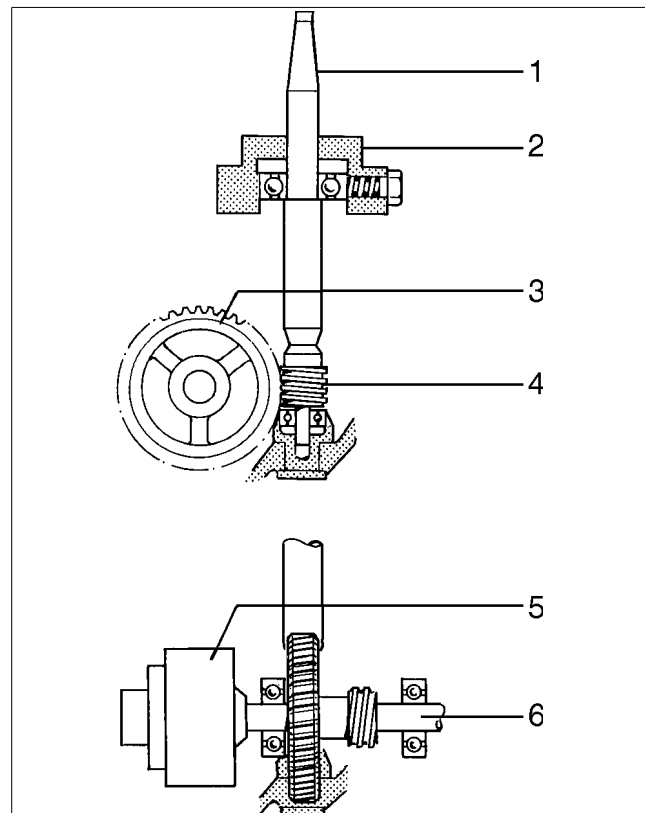

G0246431

1. Bowl spindle
2. Top bearing and spring casing
3. Worm wheel
4. Worm
5. Friction coupling
6. Worm wheel shaft

3.4.3 Brake

The separator is equipped with a hand operated brake to be used when stopping the separator. The use of the brake reduces the retardation time of the bowl and critical speeds will therefore be quickly passed.

The brake lining acts on the outside of the bowl body.

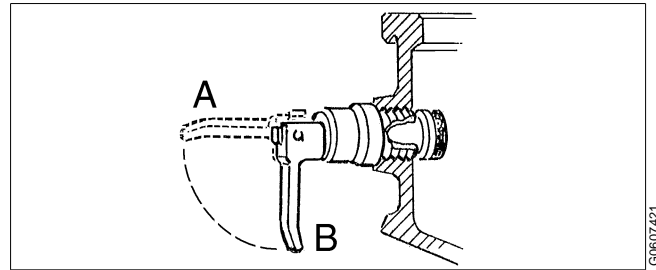

Applying (A) and releasing (B) of brake

3.4.4 Inlet and outlet pump

A gear pump is attached to the driving spindle and located on the side of the separator. This pump has dual function. It is the feed inlet pump and the clean oil discharge pump.

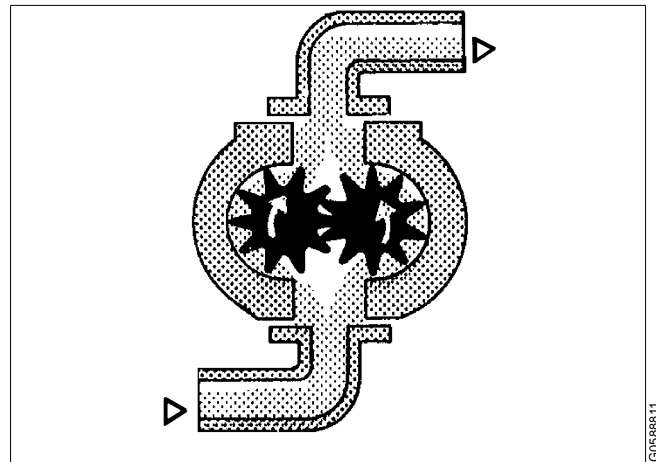

Gear pump

3.4.5 Sensors and indicators

Revolution counter

A revolution counter indicates the speed of the separator and is driven from the worm wheel shaft. The correct speed is needed to achieve the best separating results and for reasons of safety. The number of revolutions on the revolution counter for correct speed is shown in chapter “8 Technical Reference” on page 115. Refer to name plate for speed particulars.

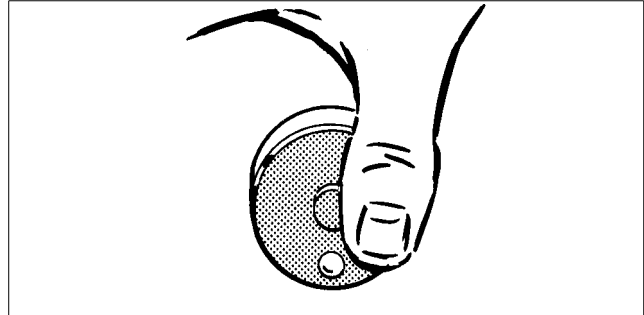

Revolution counter

Sight glass

The sight glass shows the oil level in the worm gear housing.

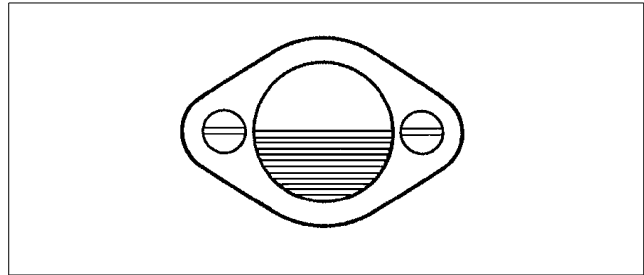

Sight glass - oil level

Cover interlocking switch (Option)

When required, the cover interlocking switch should be connected to the starter equipment so that starting of the motor is prevented when the separator collecting cover is not (completely) closed.

The switch is described in “8.8.8 Machine plates and safety labels” on page 148.

3.5 Definitions

Back pressure	Pressure in the separator outlet.
Clarification	Liquid/solids separation with the intention of separating particles, normally solids, from a liquid (oil) having a lower density than the particles.
Clarifier disc	An optional disc, which replaces the gravity disc in the separator bowl, in the case of clarifier operation. The disc seals off the heavy phase (water) outlet in the bowl, thus no liquid seal exists.
Counter pressure	See Back pressure.
Density (specific gravity)	Mass per volume unit. Expressed in kg/m ³ at specified temperature, normally at 15 °C.
Gravity disc	Disc in the bowl hood for positioning the interface between the disc stack and the outer edge of the top disc. This disc is only used in purifier mode.
Interface	Boundary layer between the heavy phase (water) and the light phase (oil) in a separator bowl.
Intermediate Service (IS)	Overhaul of separator bowl, inlet/outlet and operating water device. Renewal of seals in bowl inlet/outlet and operating water device.
Major Service (MS)	Overhaul of the complete separator, including bottom part (and activities included in an Intermediate Service, if any). Renewal of seals and bearings in bottom part.
Purification	Liquid/liquid/solids separation with the intention of separating two intermixed and mutually insoluble liquid phases of different densities. Solids having a higher density than the liquids can be removed at the same time. The lighter liquid phase (oil), which is the major part of the mixture, shall be purified as far as possible.
Sediment (sludge)	Solids separated from a liquid.
Throughput	The feed of process liquid to the separator per time unit. Expressed in m ³ /or lit/h.
Viscosity	Fluid resistance against movement. Normally expressed in centistoke (cSt = mm ² /sec), at specified temperature.
Water seal	Water in the solids space of the separator bowl to prevent the light phase (oil) from leaving the bowl through the heavy phase (water) outlet, in purifier mode.

4 Operating Instructions

Contents

4.1 Operating routine	30
4.1.1 Before first start	30
4.1.2 Selection of gravity disc	30
4.1.3 Before normal start	31
4.1.4 Starting and running-up procedure	32
4.1.5 At full speed	34
4.1.6 During operation	35
4.1.7 Stopping procedure	35
4.1.8 Emergency stop	36
4.2 Cleaning the bowl	37
4.2.1 Removal of separated sludge	37
4.2.2 Sediment paper	39
4.2.3 Disc stack	39
4.2.4 Assembling the bowl	40

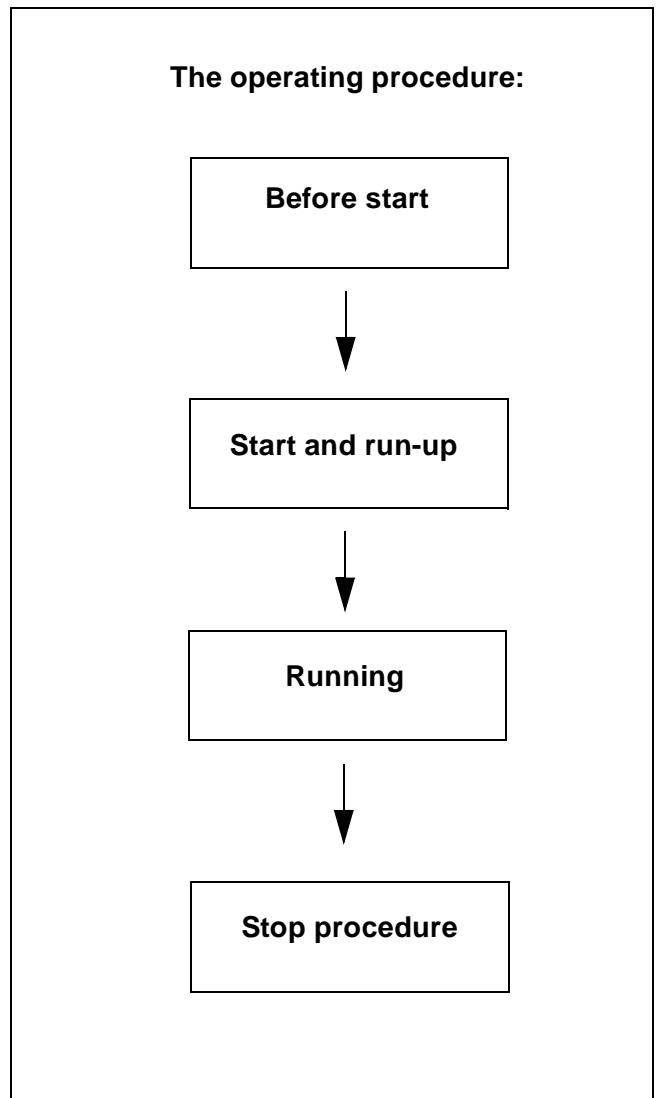

4.1 Operating routine

These instructions is related only the separator itself. If the separator is a part of a system or module follow also the instructions for the system.

4.1.1 Before first start

Technical demands for connections and logical limitations for the separator is described in the chapter "8 Technical Reference" on page 115 in the documents:

1. Technical data
2. Basic size drawing
3. Connection list
4. Interface description
5. Foundation drawing.

Before first start the following checkpoint shall be checked:

- Ensure the machine is installed correctly and that feed-lines and drains have been flushed clean.
- Fill oil in the gear housing. Fill up to the middle of the sightglass. Use the correct grade of oil. The separator is delivered without oil in the worm gear housing. For grade and quality, see "8.7 Lubricants" on page 131.

4.1.2 Selection of gravity disc

The separator is delivered with a set of gravity discs. The diameter (d) of the gravity disc sets the position of the oil-water interface in the separator. The separation efficiency can be optimized by selection of the correct diameter for each process.

As a guide the nomogram in chapter "8.1.1 Gravity disc nomogram" on page 120 can be used.

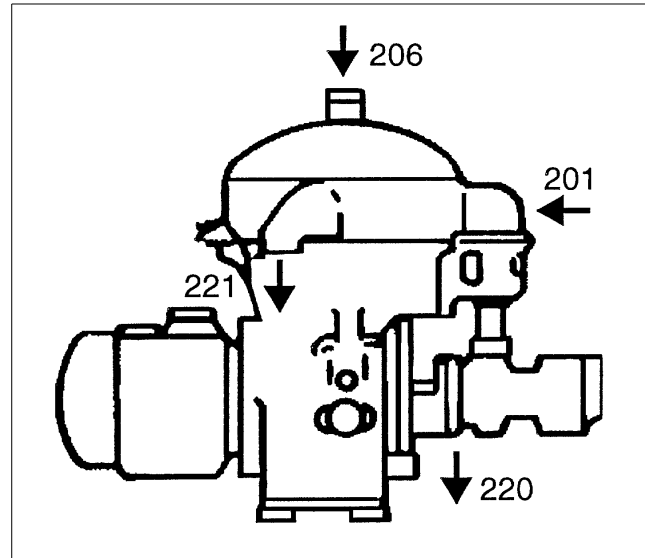

An explanation of the separator connections is given in "8.3 Connection list" on page 124

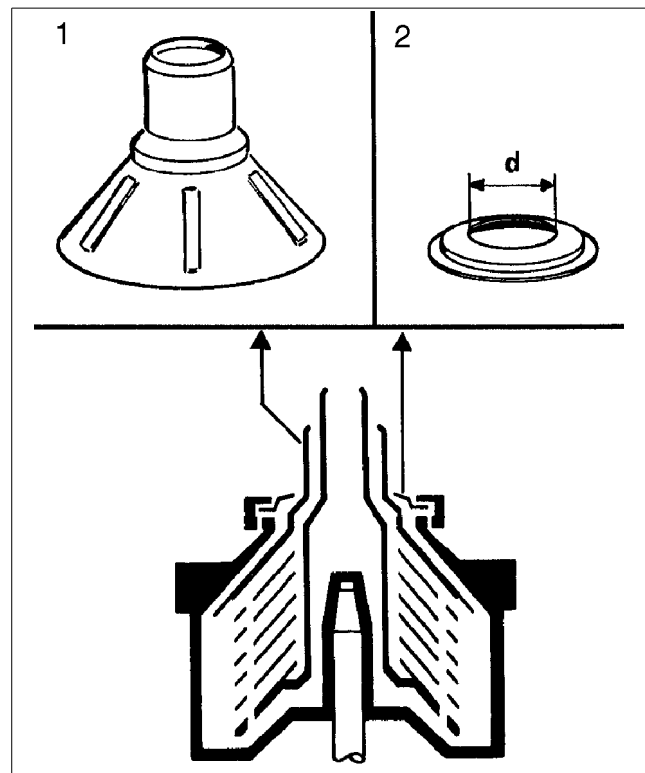

The gravity disc sets the position of oil-water interface

4.1.3 Before normal start

Check these points before every start.

1. Ensure the bowl is clean and that the separator is properly assembled.

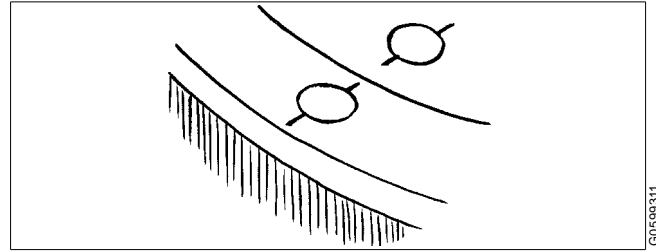

G0699311

2. Make sure that all inlet and outlet couplings and connections have been correctly made and are properly tightened to prevent leakage.

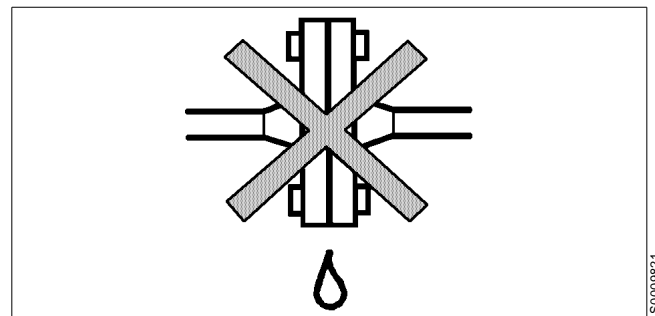

S0009821

3. Check that the bolts of the outlet cover and the hooks and screws for the frame hood are tightened.

4. Read the oil level. The middle of the sight glass indicates the **minimum** level. Refill if necessary. For grade and quality, see "8.7 Lubricants" on page 131.

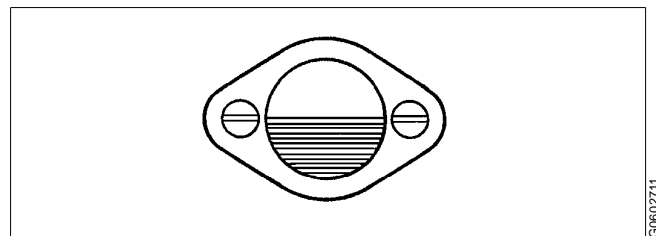

G0602711

5. Release the brake (B).

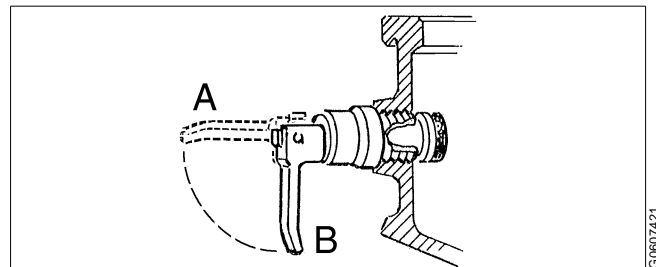

G0607421

6. Make sure the direction of rotation of the motor and bowl corresponds to the sign on the frame.

4.1.4 Starting and running-up procedure

1. After starting the separator, visually check to be sure that the motor and separator have started to rotate.
2. Check the direction of rotation. The revolution counter should run clockwise.

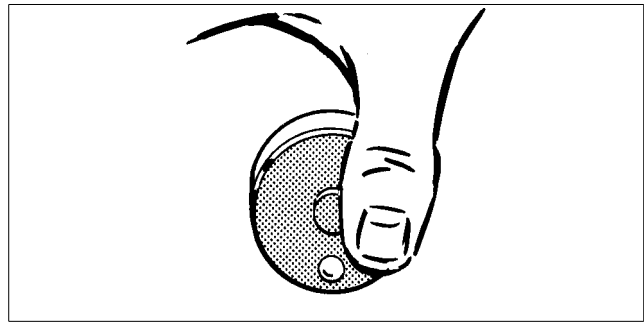

Revolution counter

3. Be alert for unusual noises or conditions. Smoke and odour may occur at the start when friction pads are new.

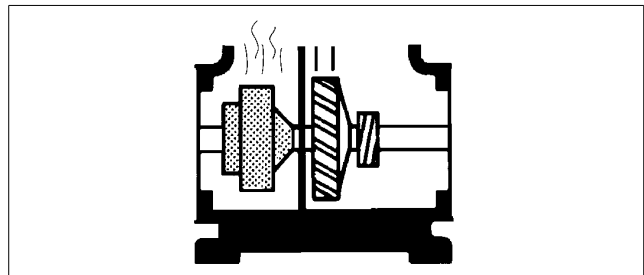

Smell

4. Note the normal occurrence of critical speed vibration periods.

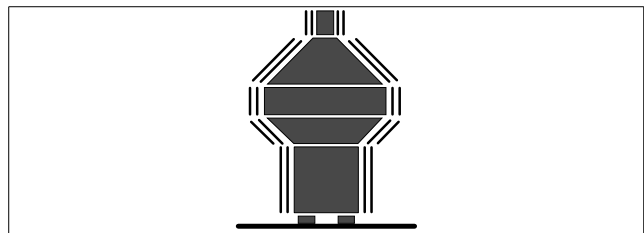

Vibration

5. Motor current indicates when the separator has come to full speed.

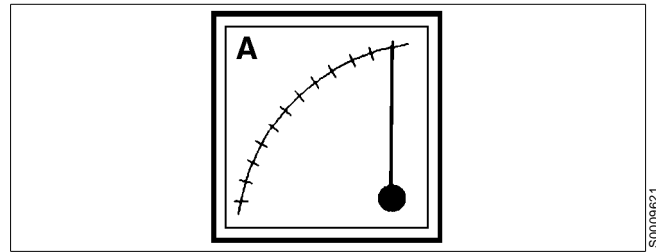

S0009621

Current increases when the coupling engages...

During start the current reaches a peak and then slowly drops to a low and stable value. For normal length of the start-up period see "8.1 Technical data" on page 116.

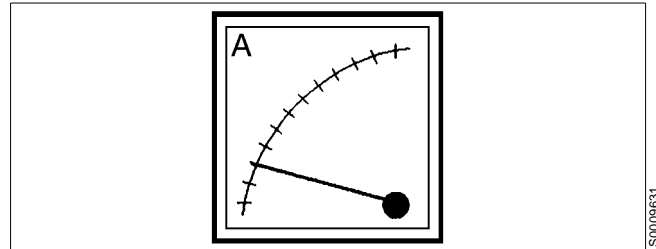

S0009631

... to decrease to a stable value when full speed has been reached



DANGER

Disintegration hazards

When excessive vibration occurs, **keep liquid feed on** and **stop** separator.

The cause of the vibrations must be identified and corrected before the separator is restarted.

Excessive vibrations may be due to incorrect assembly or poor cleaning of the bowl.

4.1.5 At full speed

1. For **purification** mode:
 - a. Supply water (206) , approx. 1 liter (depending on Gravity disc) to form the water-seal. Continue until water flows out through the water outlet (221). The water should have the same temperature as the process liquid and be supplied quickly.
 - b. Close water feed.
 - c. Start the oil feed slowly to avoid breaking the water seal. Fill the bowl as quickly as possible.
2. For **clarification** mode:
 - a. Start the oil feed with full flow. Fill the bowl as quickly as possible.
3. For both **purification** and **clarification** mode:

Check the separator inlet and outlet pressures.

Adjust the oil outlet pressure to 1,5-2 bar.
For permissible pressures, see section "8.1 Technical data" on page 116.
4. Adjust to desired throughput.

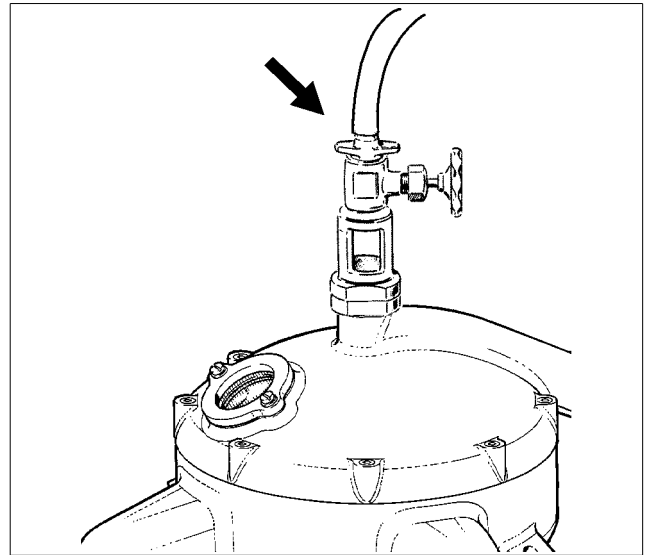

Using water adding device, see "8.8.3 Water adding device (option)" on page 141

4.1.6 During operation

Do regular checks on:

- oil inlet temperature (if applicable)
- water collecting tank level
- sound/vibration of the separator
- back pressure
- motor current.

4.1.7 Stopping procedure

1. Feed sealing water.
2. Turn off the oil feed.
3. Stop the separator.
4. Pull the brake. (A)

Wait until the separator has come to a complete standstill (2-5 minutes).

Release the brake when the separator is at standstill. (B)

5. Manual cleaning should be carried out before next start up. See "4.2.1 Removal of separated sludge" on page 37.

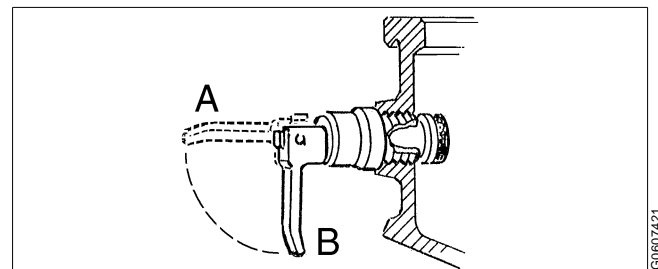

G00607421



DANGER

Entrapment hazards

Make sure that rotating parts have come to a **complete standstill** before starting **any** dismantling work.

The revolution counter and the motor fan indicate if the separator is rotating or not.

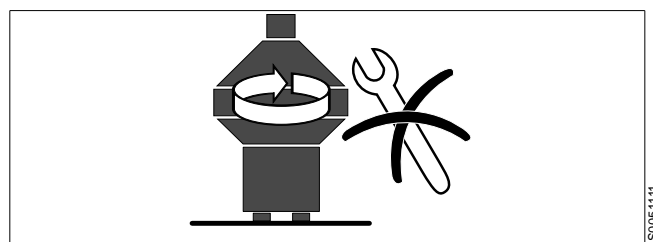

S0051111

4.1.8 Emergency stop

The emergency stop is always installed according to local safety regulations. It is often a button placed on the wall near the separator or on the control equipment.

The following should happen automatically:

- The bowl is kept filled with liquid until standstill.
- The separator motor is switched off.

Evacuate the room. The separator may be hazardous when passing resonance frequencies during the run-down.

After an emergency stop the cause of the fault must be identified.

If all parts have been checked and the cause remains unclear contact your Alfa Laval representative for advice.

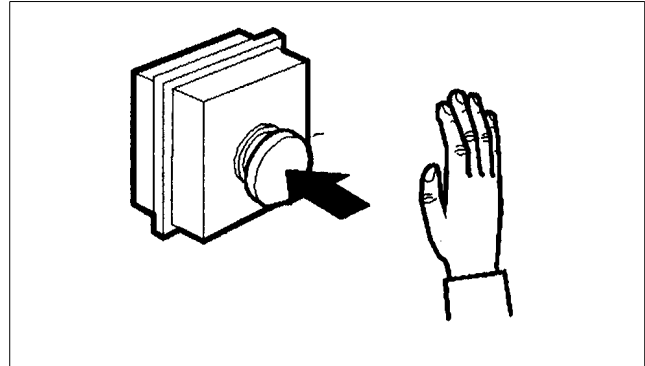

Emergency stop

SC009911

4.2 Cleaning the bowl

The separated sludge is accumulating on the inside surface of the separator bowl. How often the separator needs to be cleaned, depends on the amount of sediment entering the separator. High solids content or high throughput has the consequence that the cleaning need to be done more often.

Guidelines for emptying intervals:

Marine diesel oil - 1 week

Lubricating oil - 1 day

Intervals for a specific case must be based on experience.

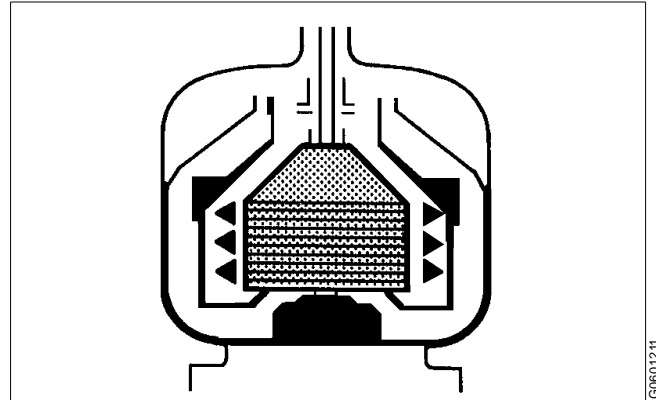

Sludge accumulation

4.2.1 Removal of separated sludge

Remove the sludge collected on the inside of the bowl as follows:

1. Stop the separator.



DANGER

Entrapment hazards

Make sure that rotating parts have come to a **complete standstill** before starting **any** dismantling work.

The revolution counter and the motor fan indicate if the separator is rotating or not.

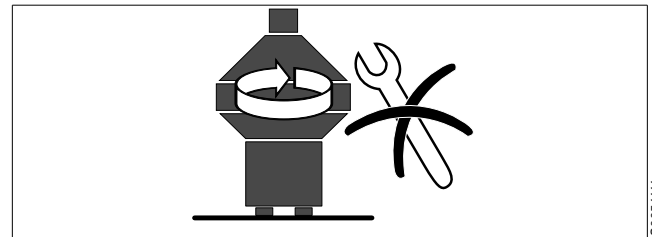

2. Raise the collecting cover open. For instructions, see chapter "6 Dismantling/ Assembly" on page 77.

3. Lock the bowl from rotating with the two lock screws.
4. Open the separator bowl.

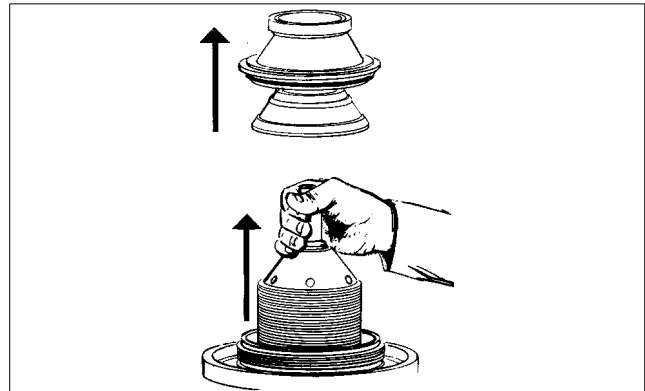

5. Clean the bowl hood.

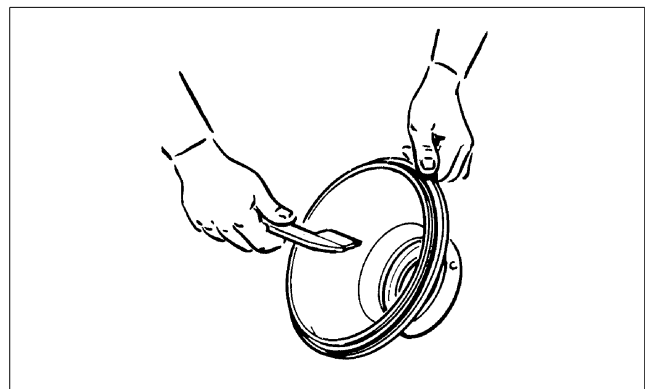

6. Clean the channels on the top disc upper side.

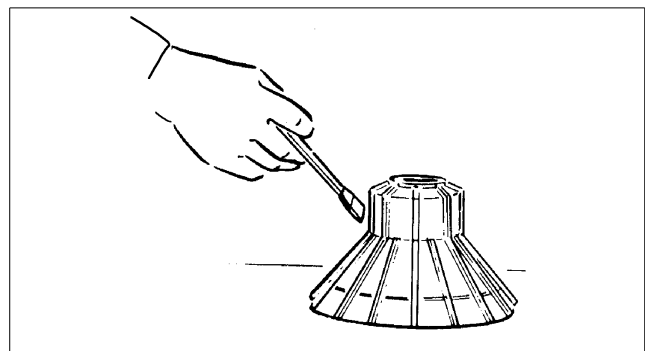

7. Remove sediment from the bowl body, clean and lubricate lock ring.

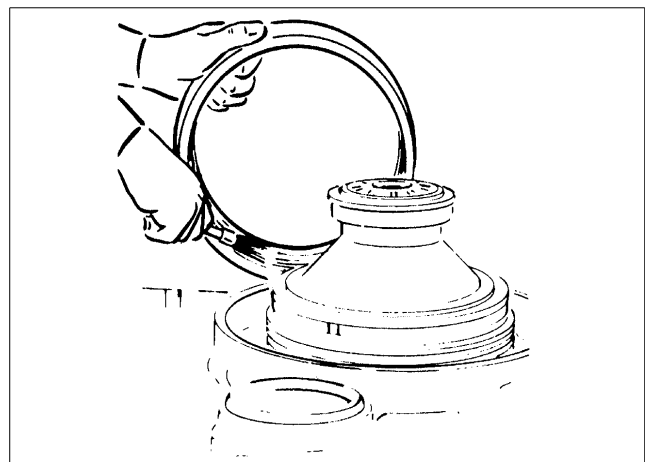

4.2.2 Sediment paper

To facilitate the cleaning of separators, a liner of plastic paper can be inserted in the bowl. Cut the paper into shape, moisten its plastic-coated side and press it against the inside of the bowl body. When cleaning remove the paper with the sediment cake.

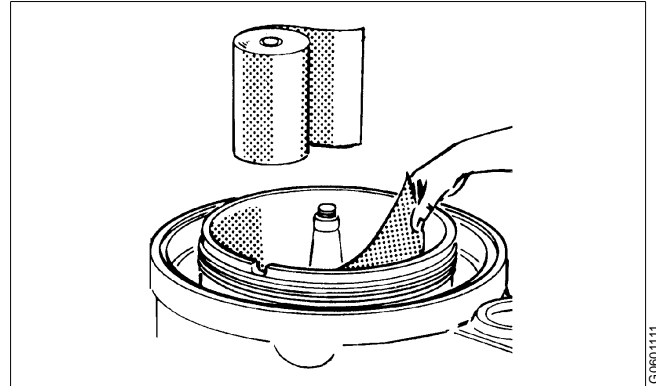

Sediment paper

4.2.3 Disc stack

When the sediment is not sticky, the disc stack can be cleaned by "hurling".

1. Clean the other bowl parts.
2. Assemble the bowl.
3. Close and lock the collecting cover.
4. Run up to full speed without liquid feed.
5. After "hurling" either continue separation or stop and open the bowl and remove the sediment.

If the sediment adheres firmly, dissolve it by submerging the distributor and the disc stack in a suitable detergent.

If "hurling" has no effect, clean the discs one by one.

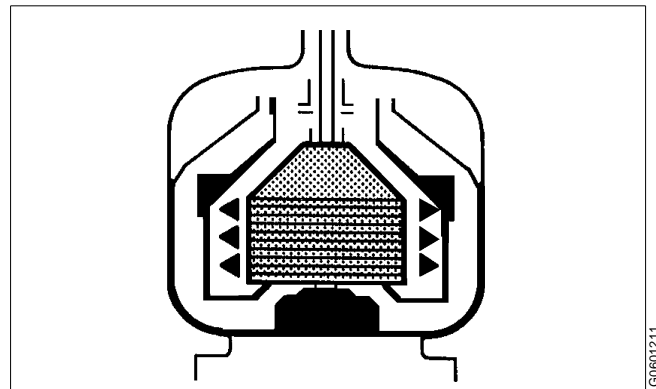

Bowl cleaning by 'hurling'

4.2.4 Assembling the bowl

Each bowl constitutes a balanced unit. Exchange of any major part necessitates rebalancing of the bowl. To prevent mixing of parts, e.g. in an installation comprising of several machines of the same type, the major bowl parts carry the machine manufacturing number or its last three digits.

NOTE
 Be sure bowl parts are not interchanged.
 Out of balance vibration will reduce ball bearing life.

Purifier bowl

The arrows indicate positions of guides on the bowl parts.

Lubrication needed



S0000711

Balanced parts.
 Exchange necessitates
 rebalancing of bowl.



S0068511

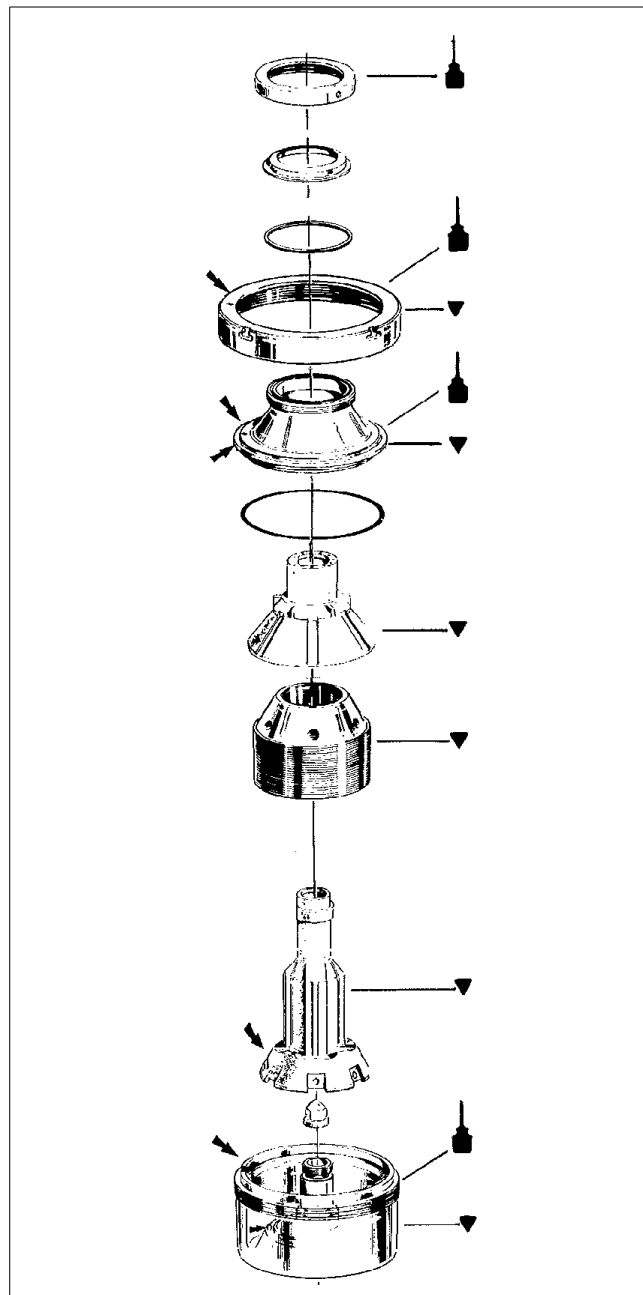

G0600311

Purifier bowl, exploded view

Clarifier bowl

The arrows indicate positions of guides on the bowl parts.

Lubrication needed



S0000711

Balanced parts.
Exchange necessitates
rebalancing of bowl.



S0068511

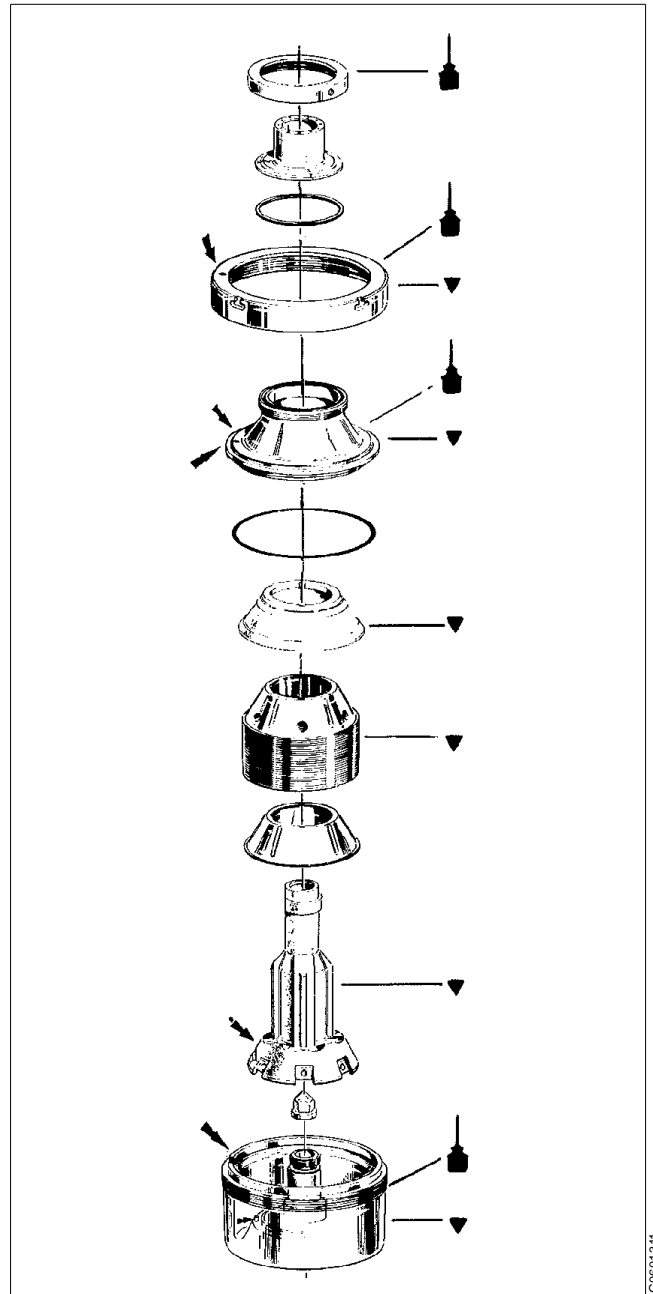

G0601311

Clarifier bowl, exploded view

1. Clean spindle top and bowl body nave with a cloth.

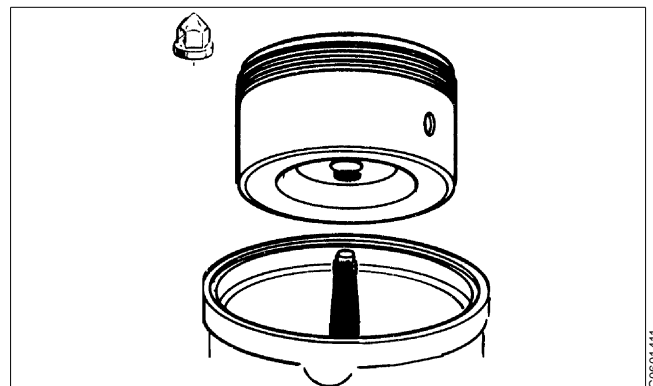

G0601411

- Bring bowl parts into positions defined by the guides.

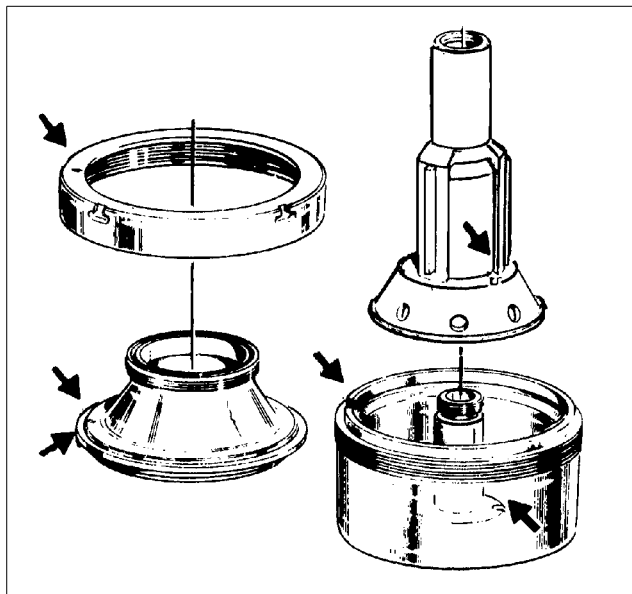

G0588911

- Screw in both lock screws. Screw large lock ring anti-clockwise until bowl hood lies tightly against bowl body.
Slacken the two lock screws.

NOTE

The two lock screws must be fully released to prevent risk for damage to bowl body.

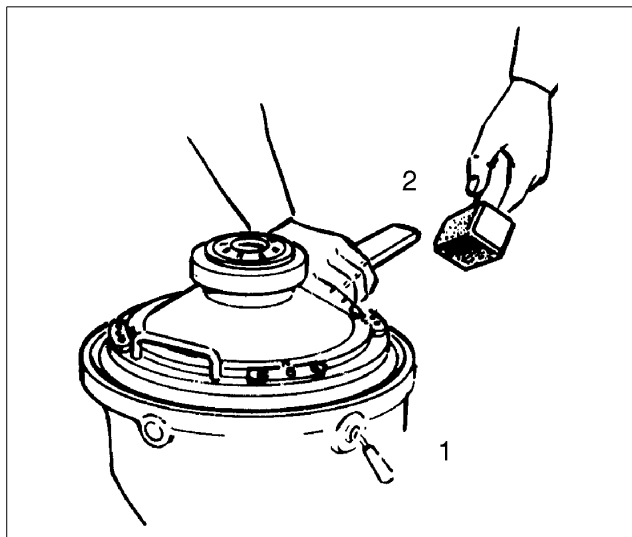

G0601511

- Lower and clamp the collecting cover and tighten the hook screws.

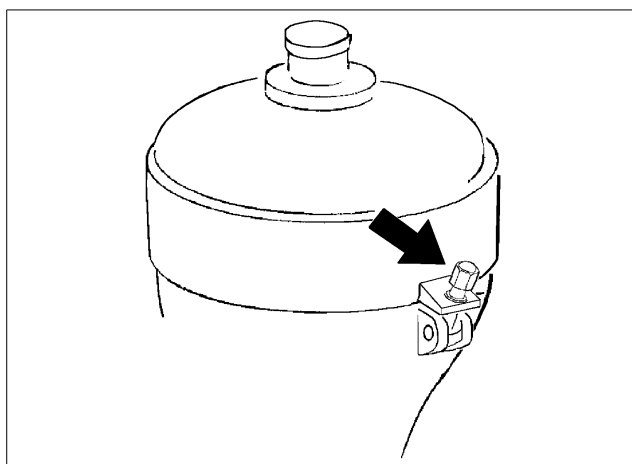

G060211

5 *Service Instructions*

Contents

5.1 Periodic Maintenance	44	5.5 When changing oil	70
5.1.1 Introduction	44	5.5.1 Oil change procedure	70
5.1.2 Maintenance intervals	44		
5.1.3 Maintenance procedure	45	5.6 Common maintenance directions	72
5.1.4 Service kits	46	5.6.1 Vibration	72
		5.6.2 Ball and roller bearings	73
5.2 Maintenance Logs	46	5.6.3 Friction coupling	74
5.2.1 Daily checks	47	5.6.4 Shutdowns	75
5.2.2 Oil change	48		
5.2.3 MS-Major Service	49	5.7 Lifting instructions	76
5.3 MS - Check points	52		
5.3.1 Corrosion	52		
5.3.2 Erosion	54		
5.3.3 Cracks	55		
5.3.4 Disc stack pressure	56		
5.3.5 Lock ring; wear and damage	56		
5.3.6 Radial wobble of bowl spindle	58		
5.3.7 Bowl spindle cone and bowl body nave	59		
5.3.8 Coupling disc of motor	60		
5.3.9 Friction pads	61		
5.3.10 Brake plug	61		
5.3.11 Top bearing springs	62		
5.3.12 Ball bearing housing	62		
5.3.13 Worm wheel and worm; wear of teeth	63		
5.3.14 Tooth appearance examples	64		
5.3.15 Cover interlocking switch, (Option)	65		
5.4 Cleaning	66		
5.4.1 External cleaning	66		
5.4.2 Cleaning agents	67		
5.4.3 Cleaning of bowl discs	69		

5.1 Periodic Maintenance

5.1.1 Introduction

Periodic (preventive) maintenance reduces the risk of unexpected stoppages and breakdowns. Maintenance schedules are shown on the following pages in order to facilitate periodic maintenance.

5.1.2 Maintenance intervals

The following directions for periodic maintenance give a brief description of which components to be cleaned, checked and renewed at different maintenance intervals.

The maintenance logs for each maintenance interval later in this chapter give detailed enumeration of the check points that must be done.

Daily checks consist of minor check points to carry out for detecting abnormal operating conditions.

After a standstill for more than six months the spindle bearings should be prelubricated before restart. See also "5.6.4 Shutdowns" on page 75.

Oil change

The oil change interval is every 1500 hours or at least once every year if the total number of operating hours is less than 1500 hours.

When using a group D oil, time of operation between oil changes can be extended from the normal 1500 hours to 2000 hours.

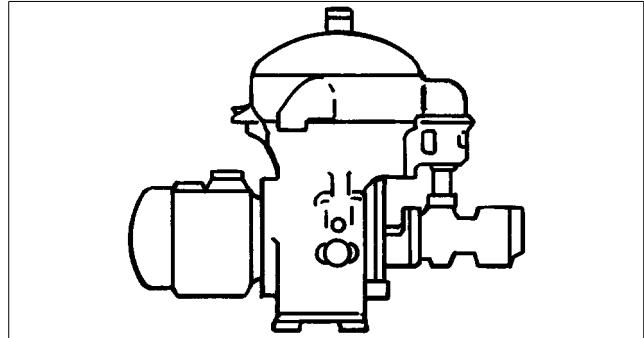

Periodic maintenance prevent stoppages

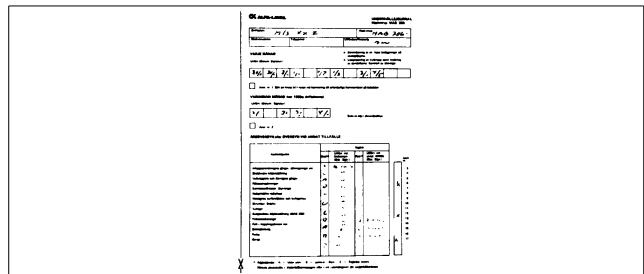

Maintenance log

MS - Major Service

Major Service consists of an overhaul of the complete separator every 12 months or 8000 operating hours. Seals and bearings in the bottom part are renewed.

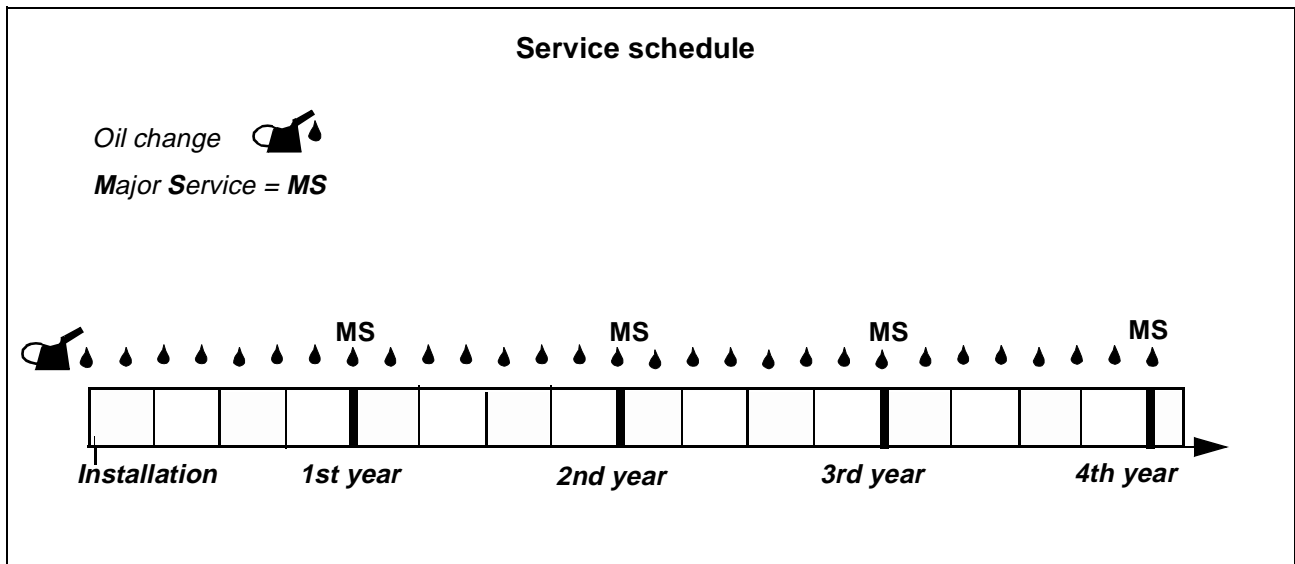

5.1.3 Maintenance procedure

At each Major Service, take a copy of the Service Log and use it for notations during the service.

A Major Service should be carried out in the following manner:

1. Dismantle the parts as mentioned in the Service Log and described in "6.2 Dismantling" on page 79.

Place the separator parts on clean, soft surfaces such as pallets.
2. Inspect and clean the dismantled separator parts according to the Service Log.
3. Fit all the parts delivered in the Service kit while assembling the separator as described in "6.3 Assembly" on page 89. The assembly instructions have references to check points which should be carried out during the assembly.

5.1.4 Service kits

Service kits are available for Major Service (MS).

For other services the spare parts have to be ordered separately.

The contents of the service kits are described in the Spare Parts Catalogue.

NOTE

Always use Alfa Laval genuine parts as otherwise the warranty will become invalid.

Alfa Laval takes no responsibility for the safe operation of the equipment if non-genuine spare parts are used.

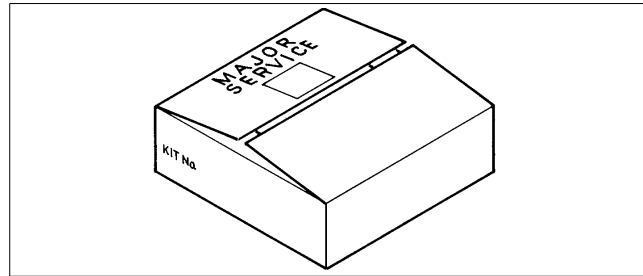

Major service kit

5.2 Maintenance Logs

Keep a log of inspection and maintenance performed. Parts repeatedly replaced should be given special consideration. The cause of repeated failures should be determined and corrected. Discuss your problems with an Alfa Laval representative and, when necessary, request a visit by an Alfa Laval Service engineer.

Rate of corrosion and erosion and notification of cracks should also be a part of this log. Note the extent of damage and date the log entries so that the rate of deterioration can be observed.

5.2.1 Daily checks

The following steps should be carried out daily.

Main component and activity	Part	Page	Notes
Inlet and outlet Check for leakage	Collecting cover and connecting housing	-	
Separator bowl Check for vibration and noise		72	
Worm wheel shaft and gear casing Check for vibration and noise Check	Oil level in gear housing	48	
Electrical motor Check for heat, vibration and noise		1)	

1) See manufacturer's instruction

5.2.2 Oil change

The oil change and check of worm gear should be carried out every 1500 * hours of operation.

Main component and activity	Part	Page	Notes
Worm wheel shaft and gear housing			
Check	Worm wheel and worm	63	
Renew	Oil * in gear housing	48	

* When using a group D oil, time of operation between oil changes can be extended from the normal 1500 hours to 2000 hours.

When the separator is running for short periods, the lubricating oil must be changed every 12 months even if the total number of operating hours is less than 1500 hours (2000 h).

In a new installation, or after replacement of gear, change the oil after 200 operating hours.

See chapter "8 Technical Reference" on page 115 for further information.

5.2.3 MS-Major Service

Name of plant: _____ Local identification: _____
 Separator: MAB 103B-24 Manufacture No./Year: _____
 Total running hours: _____ Product No: 881145-09-01
 Date: _____ Signature: _____

Main component and activity	Part	Page	Notes
Inlet and outlet Clean and inspect	Threads of inlet pipe(s)	-	
	Connecting housing	-	
Separator bowl Clean and check	Lock ring	56	
	Bowl hood	37	
	Top disc	-	
	Gravity disc	-	
	Bowl discs	-	
	Distributor	-	
	Bowl body	-	
	Corrosion	52	
	Erosion	54	
	Cracks	55	
Disc stack pressure	56		
Renew	O-rings and sealings	-	

Name of plant: _____ Local identification: _____
 Separator: MAB 103B-24 Manufacture No./Year: _____
 Total running hours: _____ Product No: 881145-09-01
 Date: _____ Signature: _____

Main component and activity	Part	Page	Notes
Worm wheel shaft and gear housing			
Check	Worm wheel and worm	63	
	Radial wobble of worm wheel shaft	-	
	Axial play of coupling disc	60	
Renew	Oil in gear housing	48	
Vertical driving device			
Clean and check	Bowl spindle	59	
	Wear of driver and of groove in worm	63	
	Buffers	58	
	Ball bearing housing indentations	62	
	Radial wobble of bowl spindle	58	
Renew	Ball bearings and top bearing springs	59	
Brake			
Clean and check	Spring and brake shoe	-	
Renew	Brake plug	61	
Pump			
Clean and check	Bushings, wearing seals, shear pin coupling and impeller shaft.	98	
Renew	Lipseal ring	98	

Name of plant:

Local identification:

Separator: MAB 103B-24

Manufacture No./Year:

Total running hours:

Product No:

881145-09-01

Date:

Signature:

Main component and activity	Part	Page	Notes
Friction coupling			
Clean and check	Friction coupling	74	
Renew	Friction pads		
Renew	Lipseal ring		
Frame feet			
Renew	Rubber cushions	104	
Electrical motor			
Clean and check	Position of coupling disc	60	
Lubrication (if nipples are fitted)	-	-	
Signs and labels on separator			
Check attachment and readability, replace if needed	Safety label on collecting cover	148	
Monitoring equipment (option)			
Function check	Cover interlocking switch	65	

NOTE

Renew all parts included in the Major Service kit (MS).

5.3 MS - Check points

5.3.1 Corrosion

Evidence of corrosion attacks should be looked for and rectified each time the separator is dismantled. Main bowl parts such as the bowl body, bowl hood and lock ring must be inspected with particular care for corrosion damage.

	<p>DANGER</p> <p>Disintegration hazard</p>
<p>Inspect regularly for corrosion damage. Inspect frequently if the process liquid is corrosive.</p>	

Always contact your Alfa Laval representative if you suspect that the largest depth of the corrosion damage exceeds 1,0 mm or if cracks have been found. Do not continue to use the separator until it has been inspected and given clearance for operation by Alfa Laval.

Cracks or damage forming a line should be considered as being particularly hazardous.

Non-stainless steel and cast iron parts

Corrosion (rusting) can occur on unprotected surfaces of non-stainless steel and cast iron. Frame parts can corrode when exposed to an aggressive environment.

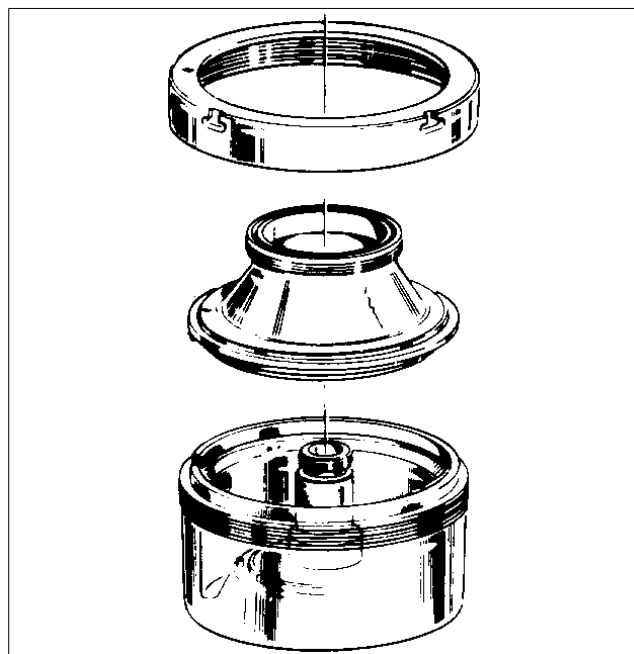

Main bowl parts

G0589811

Stainless steel

Stainless steel parts corrode when in contact with either chlorides or acidic solutions. Acidic solutions causes a general corrosion. The chloride corrosion is characterised by local damage such as pitting, grooves or cracks. The risk of chloride corrosion is higher if the surface is:

- Exposed to a stationary solution.
- In a crevice.
- Covered by deposits.
- Exposed to a solution that has a low pH 7.5
- value.

Corrosion damage caused by chlorides on stainless steel begins as small dark spots that can be difficult to detect.

- Inspect closely for all types of damage by corrosion and record these observations carefully.
- Polish dark-coloured spots and other corrosion marks with a fine grain emery cloth. This may prevent further damage.

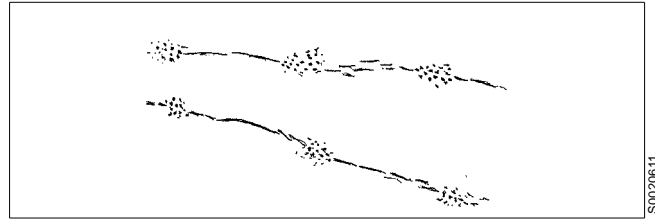

Corrosion forming a line

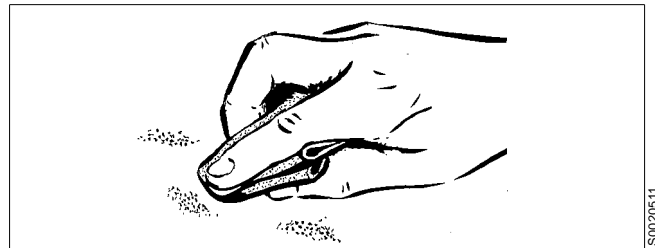

Polish corrosion spots



DANGER

Disintegration hazard

Pits and spots forming a line may indicate cracks beneath the surface.

All forms of cracks are a potential danger and are totally unacceptable.

Replace the part if corrosion can be suspected of affecting its strength or function.

Other metal parts

Separator parts made of materials other than steel, such as brass or other copper alloys, can also be damaged by corrosion when exposed to an aggressive environment. Possible corrosion damage can be in the form of pits and/or cracks.

5.3.2 Erosion

Erosion can occur when particles suspended in the process liquid slide along or strike against a surface. Erosion can become intensified locally by flows of higher velocity.



DANGER

Disintegration hazard

Inspect regularly for erosion damage. Inspect frequently if the process liquid is erosive.

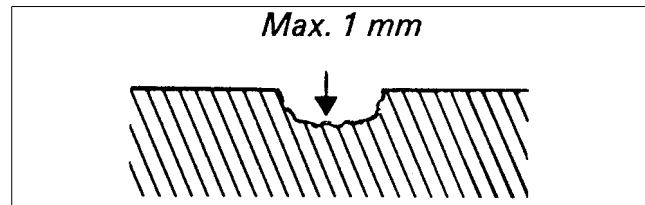

Maximum depth of damage

Always contact your Alfa Laval representative if the largest depth of any erosion damage exceeds 1,0 mm. Valuable information as to the nature of the damage can be recorded using photographs, plaster impressions or hammered-in lead.

Erosion is characterised by:

- Burnished traces in the material.
- Dents and pits having a granular and shiny surface.

Surfaces particularly subjected to erosion are:

1. The underside of the distributor in the vicinity of the distribution holes and wings.
2. The internal surface of the bowl body that faces the conical part of the distributor.

Look carefully for any signs of erosion damage. Erosion damage can deepen rapidly and consequently weaken parts by reducing the thickness of the metal.



DANGER

Disintegration hazard

Erosion damage can weaken parts by reducing the thickness of the metal. Replace the part if erosion can be suspected of affecting its strength or function.

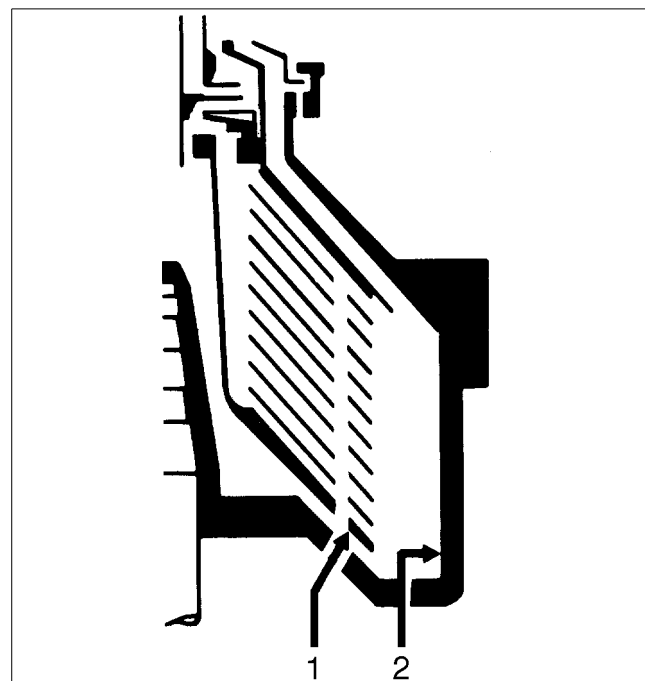

Erosion check points

5.3.3 Cracks

Cracks can initiate on the machine after a period of operation and propagate with time.

- Cracks often initiate in an area exposed to high cyclic material stresses. These are called fatigue cracks.
- Cracks can also initiate due to corrosion in an aggressive environment.
- Although very unlikely, cracks may also occur due to the low temperature embrittlement of certain materials.

The combination of an aggressive environment and cyclic stresses will speed-up the formation of cracks. Keeping the machine and its parts clean and free from deposits will help to prevent corrosion attacks.



DANGER

Disintegration hazard

All forms of cracks are potentially dangerous as they reduce the strength and functional ability of components.

Always replace a part if cracks are present.

It is particularly important to inspect for cracks in rotating parts.

Always contact your Alfa Laval representative if you suspect that the largest depth of the damage exceeds 1,0 mm. Do not continue to use the separator until it has been inspected and cleared for operation by Alfa Laval.

5.3.4 Disc stack pressure

The lock ring (1) should press the bowl hood (2) firmly against the bowl body (3). The hood in turn should exert a pressure on the disc stack (4), clamping it in place.

NOTE

Insufficient pressure in disc stack can cause out of balance vibration and reduced lifetime of ball bearings.

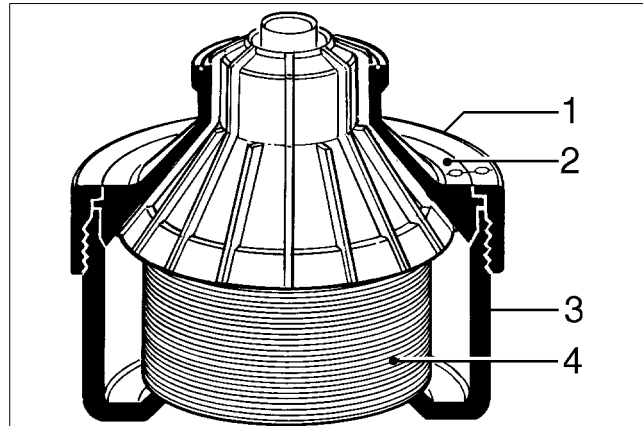

Disc stack pressure check

Compress the disc stack by tightening the lock ring, see chapter "6.3.3 Bowl" on page 94.

Correct pressure is obtained when it is possible to tighten the lock ring so far by hand that the ϕ -mark on the lock ring is positioned 60° - 90° before the mark on the bowl hood.

To achieve this, add an appropriate number of discs to the top of the disc stack beneath the top disc.

Then advance the lock ring by giving the spanner handle some blows till the ϕ -marks are passed and the bowl is fully assembled.

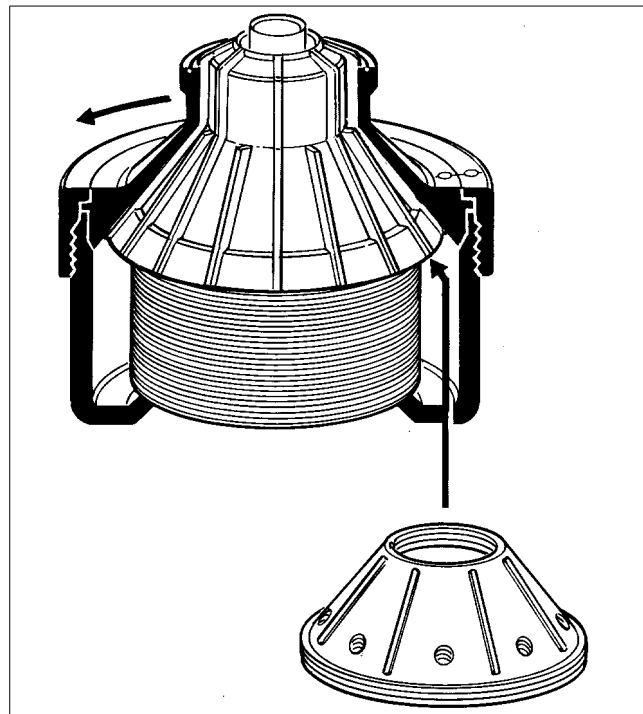

Add discs to achieve disc stack pressure

5.3.5 Lock ring; wear and damage

Excessive wear or impact marks on threads, guide and contact surfaces of the lock ring, bowl hood and bowl body may cause hazardous galling.

Check the thread condition by tightening the lock ring after removing the disc stack and bowl hood O-ring from the bowl.

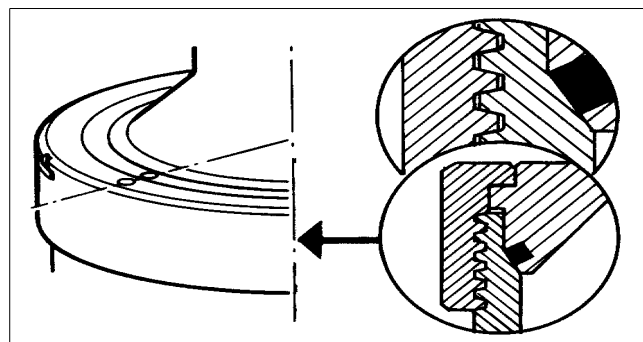

Wear of lock ring

**DANGER****Disintegration hazards**

Wear on large lock ring thread must not exceed safety limit. The ϕ -mark on lock ring must not pass opposite ϕ -mark by more than the specified distance.

In a new bowl the alignment marks on the lock ring and the bowl hood are exactly opposite each other.

If thread wear is observed, mark the bowl hood at the new position of the alignment mark on the lock ring by punching in a new alignment mark.

Contact Your Alfa Laval representative

- If the original mark on the lock ring passes the corresponding mark on the bowl hood by more than 25° (or 25 mm).
- If the alignment marks become illegible. The thread wear need to be inspected and the new position of alignment marks determined.

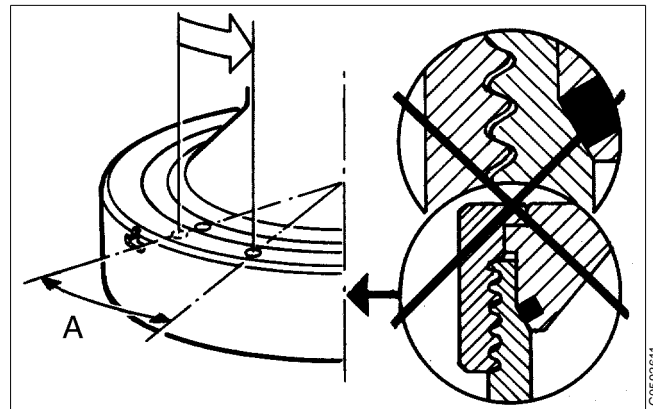

Maximum wear $A=25^\circ$ (or 25 mm)

Damage

The position of the threads, contact and guide surfaces are indicated by arrows in the illustration.

Clean the threads, contact and guide surfaces with a suitable degreasing agent.

Check for burrs and protrusions caused by impact. Watch your fingers for sharp edges.

If damage is established, rectify using a whetstone or fine emery cloth (recommended grain size 240).

If the damage is considerable, use a fine single-cut file, followed by a whetstone.

5.3.6 Radial wobble of bowl spindle

- Spindle wobble is indicated by rough bowl run (vibration).

The bowl spindle wobble should be checked if the bowl spindle has been dismantled or if rough bowl running (vibration) occurs.

NOTE

Spindle wobble will cause rough bowl run. This leads to vibration and reduces lifetime of ball bearings.

Check the wobble before mounting the bowl.

Before measuring, make sure that the buffer plugs are properly tightened.

- Fit a dial indicator in a support and fasten it to the frame.
- Remove the motor to get access to the coupling drum. Use the coupling drum to revolve the spindle manually.
- Measure the wobble at the top of the tapered end of the spindle. Maximum permissible radial wobble is 0,15 mm.
- If wobble is too large, renew all the ball bearings on the spindle.

Measure wobble after assembly. If it is still excessive, the spindle is probably damaged and must be replaced, contact your Alfa Laval representative.

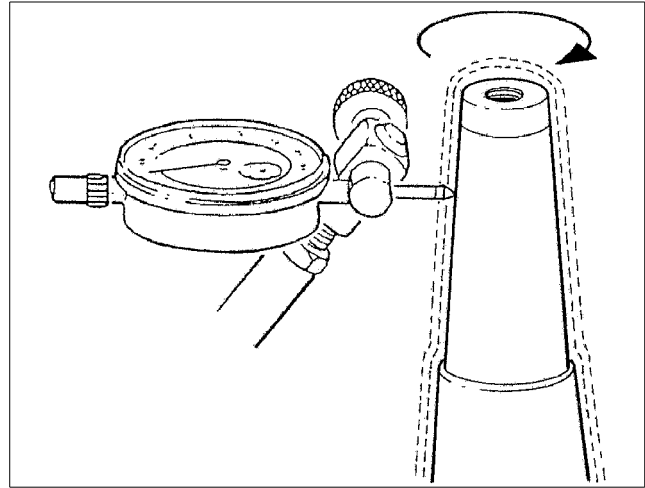

Maximum spindle wobble 0,15 mm

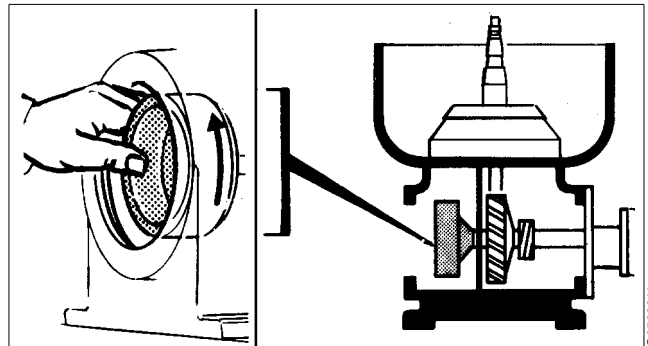

Rotate spindle by hand

5.3.7 Bowl spindle cone and bowl body nave

Impact marks on the spindle cone or in the bowl body nave may cause poor fit and out-of-balance vibrations.

The bowl spindle and the nave should also be checked if the bowl spindle has been dismantled or if the bowl runs roughly.

Corrosion may cause the bowl to stick firmly to the spindle cone and cause difficulties during the next dismantling.

- Remove any impact marks with a scraper and/or whetstone.

Rust can be removed by using a fine-grain emery cloth (e.g. No 320).

Finish with polishing paper (e.g. No 600).

Wipe off the spindle top and nave bore in the bowl body. Lubricate the tapered end of the spindle and wipe it of with a clean cloth before assembling.

NOTE

Always use a scraper with great care. The conicity must not be marred.

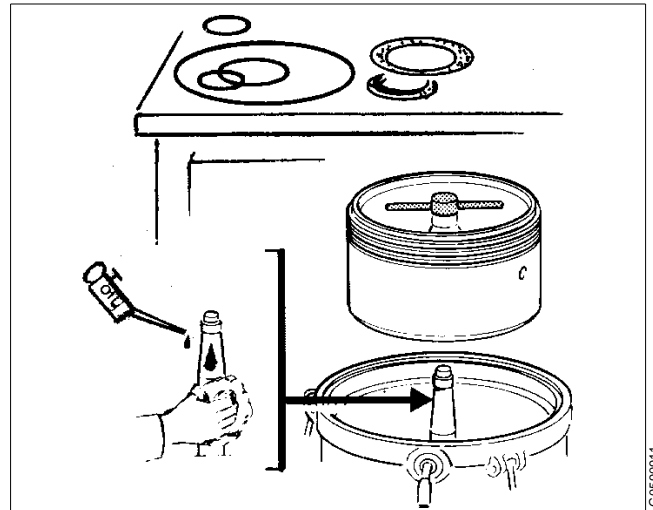

Put a little oil on the bowl spindle and wipe it of with a clean cloth to prevent corrosion

5.3.8 Coupling disc of motor

The position of the coupling disc on the motor shaft is establishing the location of the friction pads inside the coupling.

If the coupling disc is loosened without first marking its position on the motor shaft, the correct position must be determined again.

1. Measure the distance on the frame.

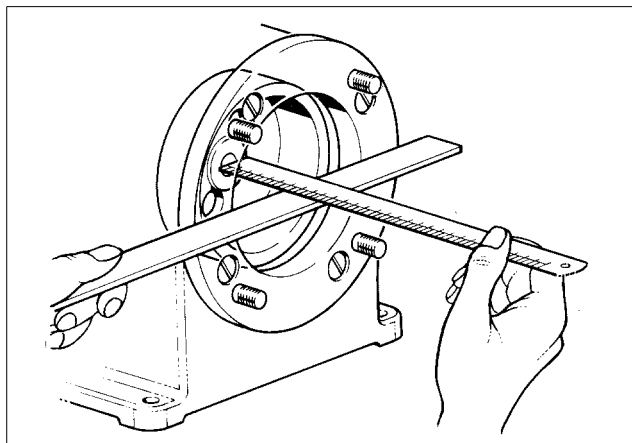

Frame distance

2. Measure the distance on the motor.

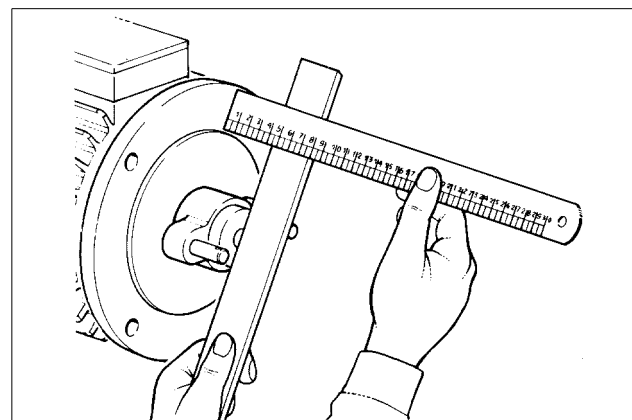

Motor distance

3. The coupling disc is in correct position when frame distance (1) is 16-17 mm larger than motor distance (2). See fig.

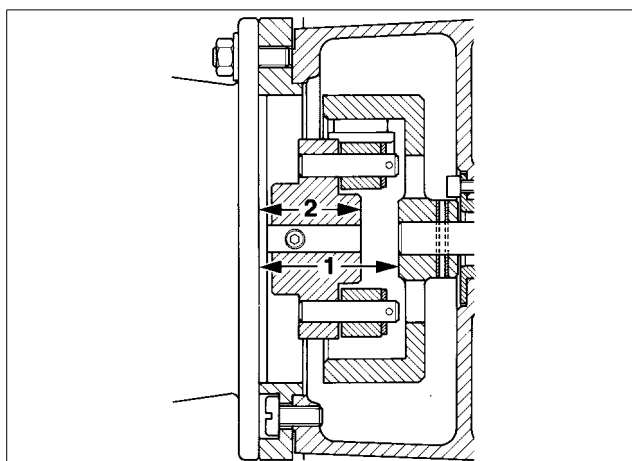

Position of coupling disc

5.3.9 Friction pads

Worn or oily pads will cause a long running-up period. Replace all the pads even when only one of them is worn.

If the pads are oily:

- Clean the pads as well as the inside of the coupling drum with a suitable degreasing agent.
- Roughen up the friction surfaces of the pads with a coarse file.

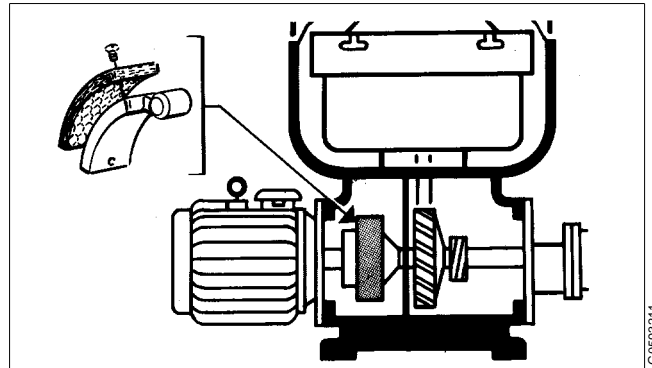

Friction coupling

5.3.10 Brake plug

A worn brake plug will cause a long stopping period.

Replace the plug when the friction material is worn. If the thickness A of the friction material is less than 0,5 mm the brake plug need to be replaced.

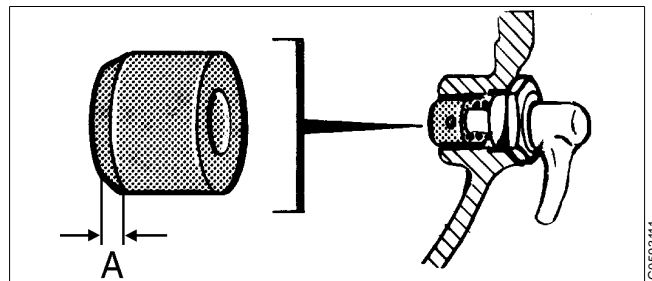

Maximum wear of brake plug when $A=0,5$ mm

5.3.11 Top bearing springs

Weakened or broken buffer springs may give rise to machine vibration (rough bowl running).

The condition (stiffness) of a spring can hardly be determined without using special testing equipment. So, an estimation of the spring condition must be based on the knowledge of the machine run before the overhaul. It is recommended, however, to replace all the springs at the annual overhaul.

In case of a sudden spring fracture, all springs should be replaced even when only one spring has broken.

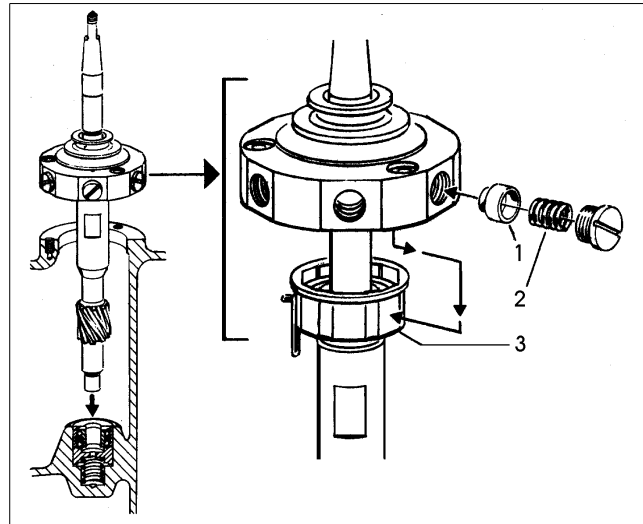

1. Radial buffer
2. Buffer spring
3. Ball bearing housing

5.3.12 Ball bearing housing

- Defective contact surfaces for the buffers on the ball bearing housing may give rise to machine vibration (rough bowl running).

Examine the contact surface for the buffers (1) on the ball bearing housing (3). In case of defects (indentations deeper than 0,1 mm) replace the housing as well as buffers and springs.

5.3.13 Worm wheel and worm; wear of teeth

Check the teeth of worm wheel and worm for wear.

See “5.3.14 Tooth appearance examples” on page 64.

Examine the contact surfaces and compare the tooth profiles. The gear may operate satisfactorily even when worn to some degree.

NOTE

Replace both worm wheel and worm at the same time, even if only one of them is worn.

NOTE

Presence of metal chips in the oil bath is an indication that the gear is wearing abnormally.

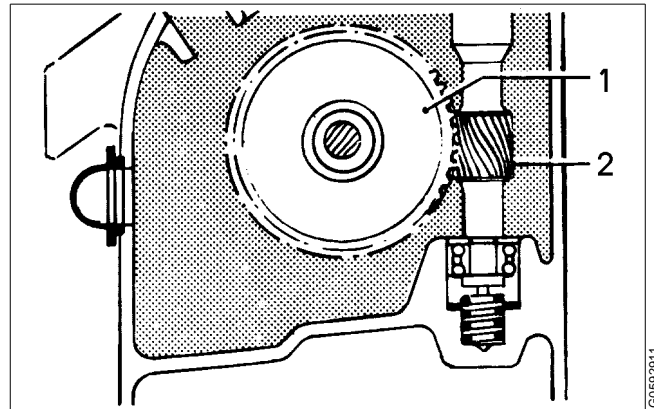

1. Worm wheel
2. Worm (part of bowl spindle)

When using mineral-type oil in the worm gear housing, the presence of black deposits on the spindle parts is an indication that the oil base has deteriorated seriously or that some of the oil additives have precipitated. If pits are found on the worm gear, the cause could be that the additives are not suitable for this purpose.

In all these cases it is imperative to change to a high-temperature oil. See chapter “8.7 Lubricants” on page 131.

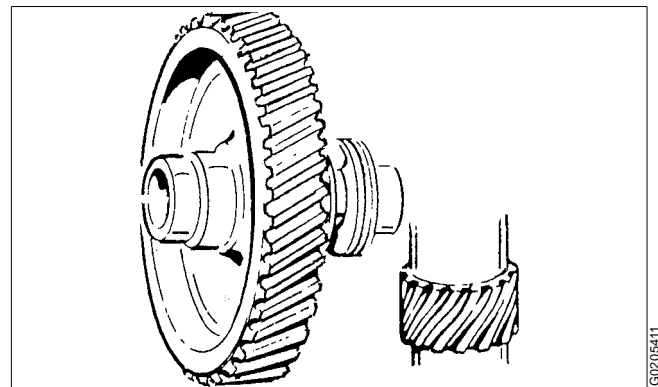

Inspect the gear for deposits and pits

5.3.14 Tooth appearance examples

Satisfactory teeth:

Uniform wear of contact surfaces. Surfaces are smooth.

Good contact surfaces will form on the teeth when the gear is subjected to only moderate load during its running-in period.

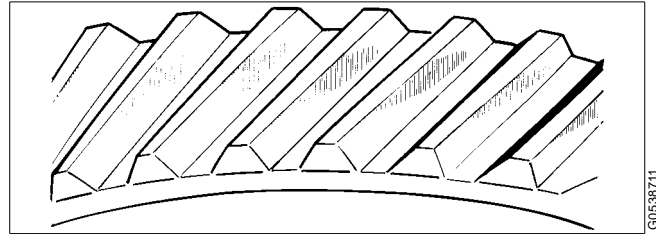

Satisfactory teeth

Worn teeth:

Permissible wear is as a rule 1/3 of the thickness of the upper part of a tooth, provided that

- the wear is uniform over the whole of the flank of a tooth
- and all teeth are worn in the same way.

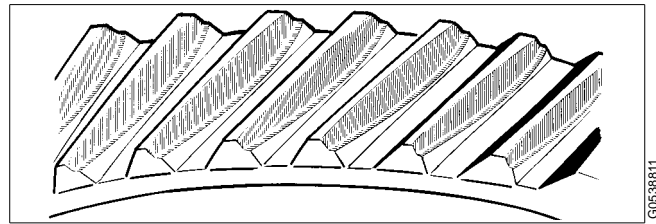

Worn teeth

Spalling:

Small bits of the teeth have broken off, so-called spalling. This is generally due to excessive load or improper lubrication. Damage of this type need not necessitate immediate replacement, but careful checking at short intervals is imperative.

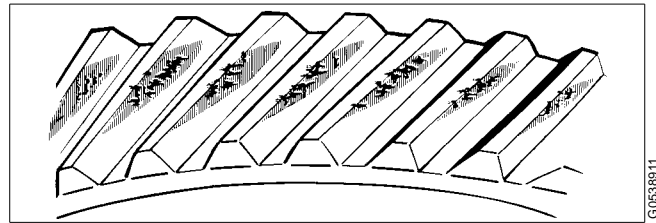

Spalling

Pitting:

Small cavities in the teeth, so-called pitting, can occur through excessive load or improper lubrication. Damage of this type need not necessitate immediate replacement, but careful check at short intervals is imperative.

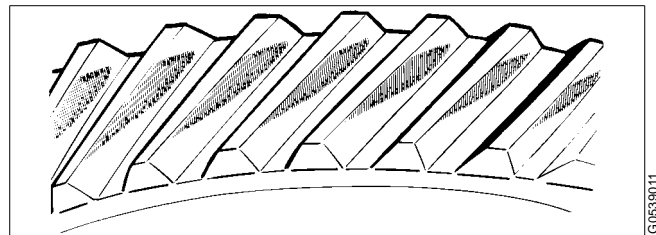

Pitting

5.3.15 Cover interlocking switch, (Option)

When the button is pressed down, check that the brown and blue wires are short-circuited and the two black wires are out-of-circuit.

Check also the reverse when the button not pressed.

See the illustration for exact measurement when the button is operated.

- Contact closed
- Contact open
- BK* Black
- BN* Brown
- BU* Blue
- GN-YW* Green-Yellow

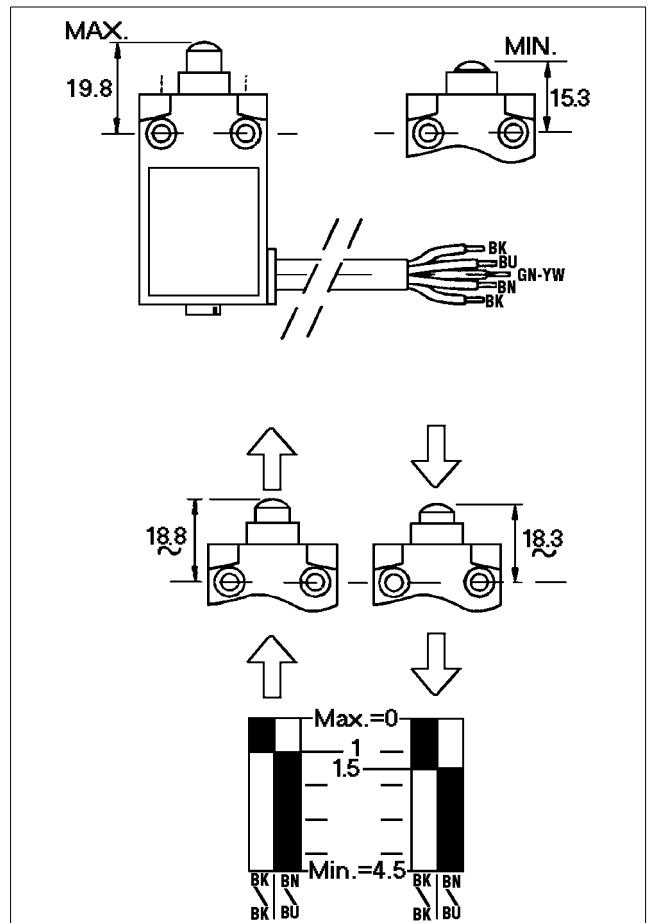

G0548111

5.4 Cleaning

5.4.1 External cleaning

The external cleaning of the frame and motor should be restricted to brushing, sponging or wiping while the motor is running or is still hot.

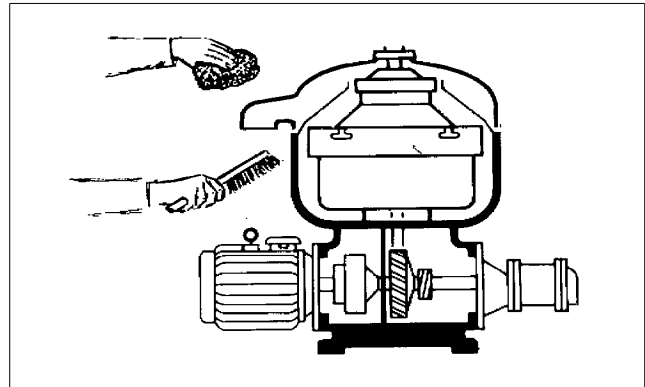

Use a sponge or cloth and a brush when cleaning

Never wash down a separator with a direct water stream.

Totally enclosed motors can be damaged by direct hosing to the same extent as open motors and even more than those, because:

- Some operators believe that these motors are sealed, and normally they are not.
- A water jet played on these motors will produce an internal vacuum, which will suck the water between the metal-to-metal contact surfaces into the windings, and this water cannot escape.
- Water directed on a hot motor may cause condensation resulting in short-circuiting and internal corrosion.

Be careful even when the motor is equipped with a protecting hood. Never play a water jet on the ventilation grill of the hood.

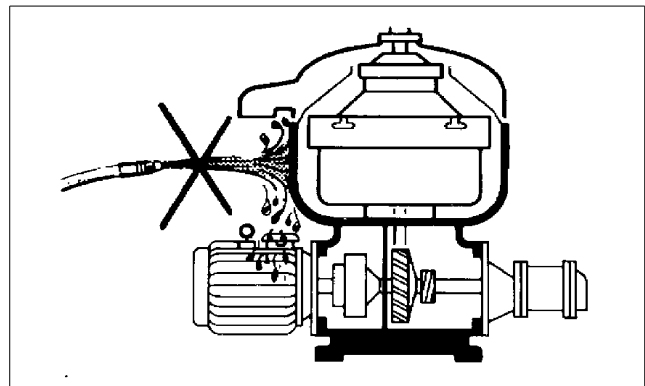

Never wash down a separator with a direct water stream. Never play a water jet on the motor

5.4.2 Cleaning agents

When using chemical cleaning agents, make sure you follow the general rules and supplier's recommendations regarding ventilation, protection of personnel, etc.

For separator bowl, inlet and outlet

A chemical cleaning agent must dissolve the deposits quickly without attacking the material of the separator parts.

- For cleaning of **lube oil** separators the most important function of the cleaning agent is to be a good solvent for the gypsum in the sludge. It should also act as a dispersant and emulsifier for oil. It is recommended to use **Alfa-Laval cleaning liquid for lube oil separators** which has the above mentioned qualities. Note that carbon steel parts can be damaged by the cleaning agent if submerged for a long time.
- **Fuel oil** sludge mainly consists of complex organic substances such as asphaltenes. The most important property of a cleaning liquid for the removal of fuel oil sludge is the ability to dissolve these asphaltenes.

Alfa Laval cleaning liquid of fuel oil separators has been developed for this purpose. The liquid is water soluble, non-flammable and does not cause corrosion of brass and steel. It is also gentle to rubber and nylon gaskets in the separator bowl.

Before use, dilute the liquid with water to a concentration of 3-5%. Recommended cleaning temperature is 50-70 °C.

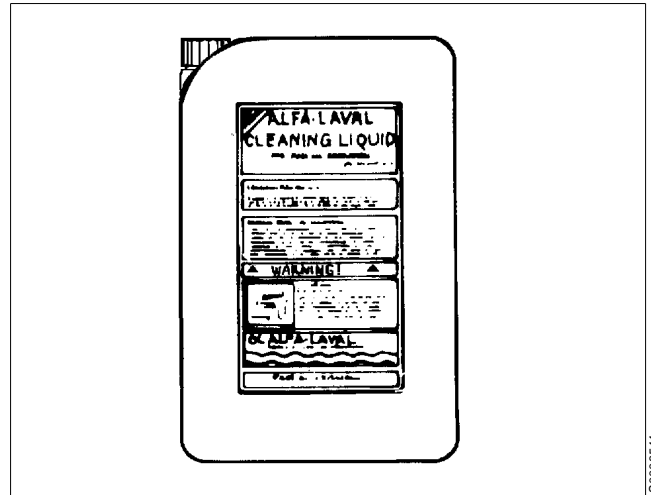

*Alfa Laval cleaning liquid for lube oil separators is available in 25-litre plastic containers.
Part No. 1762852-01.*

*Alfa Laval cleaning liquid for fuel oil separators is available in 5-litre plastic containers.
Part No. 1763500-01.*



CAUTION

Skin irritation hazard

Read the instructions on the label of the plastic container before using the cleaning liquid.

Always wear safety goggles, gloves and protective clothing as the liquid is alkaline and dangerous to skin and eyes.

For parts of the driving devices

Use white spirit, cleaning-grade kerosene or diesel oil.

Oiling (protect surfaces against corrosion)

Protect cleaned carbon steel parts against corrosion by oiling. Separator parts that are not assembled after cleaning must be wiped and coated with a thin layer of clean oil and protected from dust and dirt.

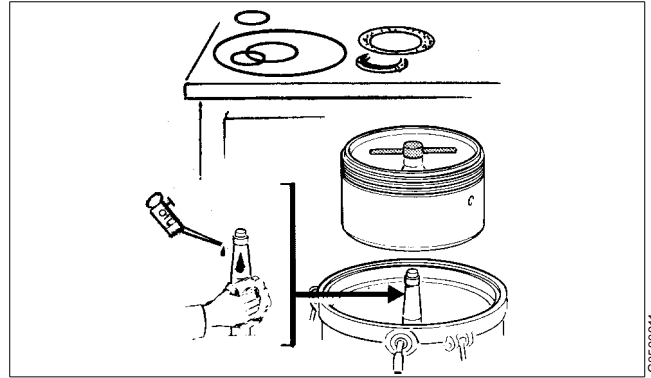

Oil parts to protect from corrosion

5.4.3 Cleaning of bowl discs

Bowl discs

Handle the bowl discs carefully so as to avoid damage to the surfaces during cleaning.

NOTE

Mechanical cleaning is likely to scratch the disc surfaces causing deposits to form quicker and adhere more firmly.

A gentle chemical cleaning is therefore preferable to mechanical cleaning.

1. Remove the bowl discs from the distributor and lay them down, **one by one**, in the cleaning agent.
2. Let the discs remain in the cleaning agent until the deposits have been dissolved. This will normally take between two and four hours.
3. Finally clean the discs with a **soft** brush.

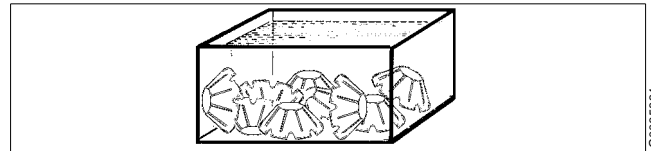

Put the discs one by one into the cleaning agent

G0065831



Clean the discs with a soft brush

G0065841



CAUTION

Cut hazard

The discs have sharp edges.

5.5 When changing oil

Check at each oil change

Check the teeth of both the worm wheel and worm for wear.

5.5.1 Oil change procedure

NOTE

Before adding or renewing lubricating oil in the worm gear housing, the information concerning different oil groups, handling of oils, oil change intervals etc. given in chapter "8 Technical Reference" on page 115 must be well known.

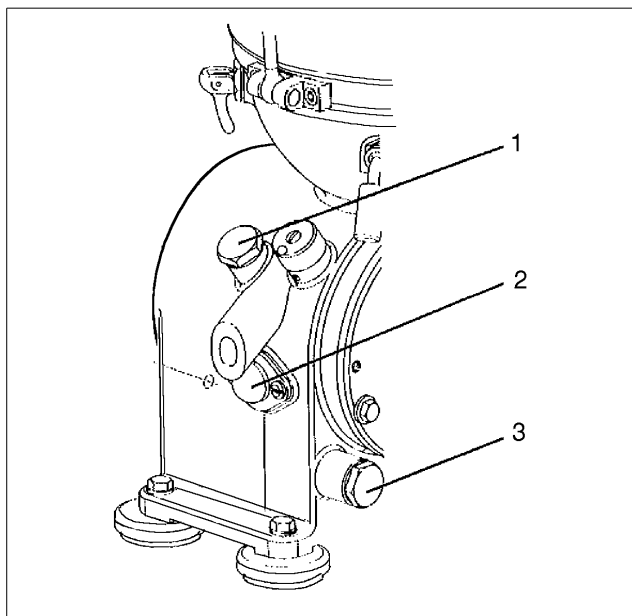

1. Oil filling plug
2. Sight glass
3. Oil drain plug

1. Place a collecting tray under the drain hole, remove the drain plug and drain off the oil.



CAUTION

Burn hazards

Lubricating oil and various machine surfaces can be sufficiently hot to cause burns.

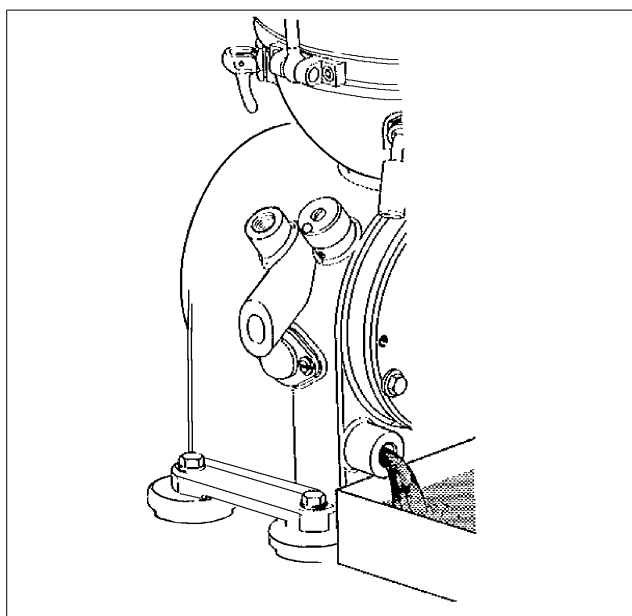

Drain oil

2. Fill new oil in the worm gear housing. The oil level should be slightly above middle of the sight glass. See chapter "8.1 Technical data" on page 116.

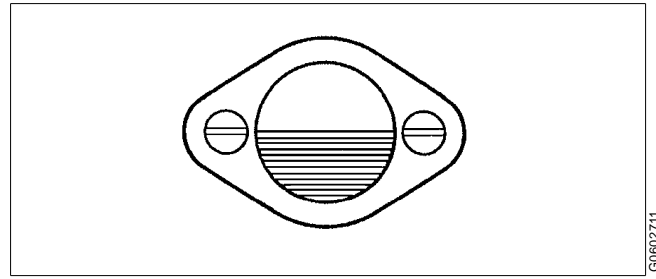

Oil level in sight glass

G0602711

5.6 Common maintenance directions

5.6.1 Vibration

A separator normally vibrates and make noises, when it passes its critical speeds, during the start and stop periods.

It is recommended to get familiar with the normal behaviour of the machine.

Severe vibrations or noise indicates that something is incorrect. Stop the machine and identify the cause.

Use vibration analysis instrument to periodically check and record the level of vibration.

The level of vibration should not exceed maximum for separator in use (7,1 mm/s).

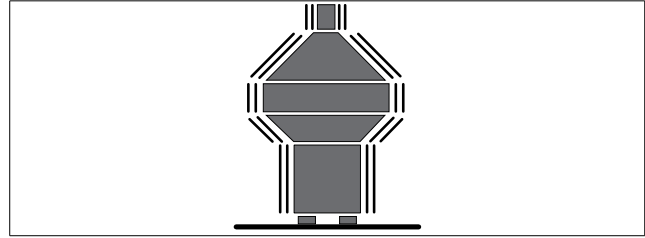

Vibration

S0055611



DANGER

Disintegration hazards

When excessive vibration occurs, **keep liquid feed on** and **stop** separator.

The cause of the vibration must be identified and corrected before the separator is restarted. Excessive vibration can be due to incorrect assembly or poor cleaning of the bowl.

5.6.2 Ball and roller bearings

Use the greatest cleanliness when handling rolling bearings. Avoid unnecessary dismantling of bearings. Do not re-fit a used bearing, always replaced it with a new one.

Important: Specially designed bearings are used for the bowl spindle.

The bearings used for the bowl spindle are specifically designed to withstand the speed, vibration, temperature and load characteristics of high-speed separators.

Do not use other bearings than those stated in the Spare Parts Catalogue.

A bearing that in appearance looks equivalent to the correct bearing may be considerably different from the latter in various respects: inside clearances, design and tolerances of the cage and ball (roller) races as well as material and heat treatment. Any deviation from the correct bearing may cause a serious breakdown.

Dismounting

Detach the bearing from its seat by pressing against the race having the tightest fit. Use a puller or a special tool to apply the pressure to the inner race when the bearing sits tightly on the shaft, and to the outer race when the bearing is tightly fitted in the housing respectively.

Arrange dismantled bearings and other parts in assembling order to avoid confusion.

Check the shaft end and the bearing seat in the housing for damage indicating that the bearing has rotated on the shaft, and in the housing respectively. Replace the damaged part, if the faults cannot be remedied by polishing or in some other way.

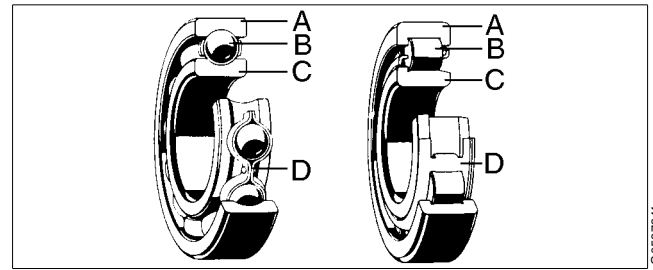

- A Outer race
- B Ball/Roller
- C Inner race
- D Cage

G0587311

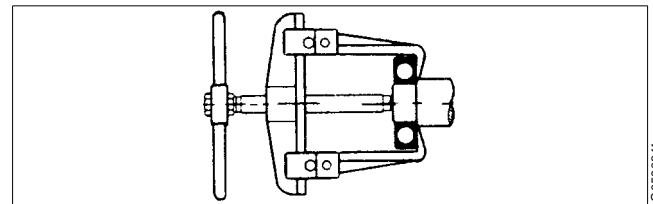

Use puller tool to dismount bearing

G0590311

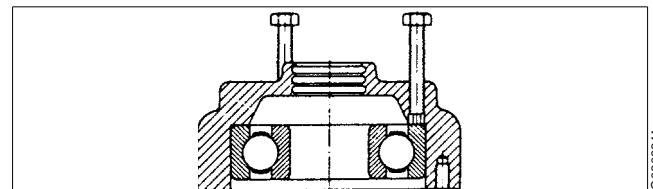

Check bearing seat

G0602211

Fitting

Leave new bearings in original wrapping until ready to fit. The anti-rust agent protecting a new bearing need not be removed.

Fit a bearing on a shaft by pressure applied to the inner race and in a housing by pressure applied to the outer race. Use a suitable piece of pipe or a metal drift and a hammer. Never strike the bearing directly.

Bearings sitting with tight fit on a shaft should be heated in oil before assembly. The oil temperature should not exceed 125 °C. Never leave the bearing in the oil bath longer than required for thorough heating.

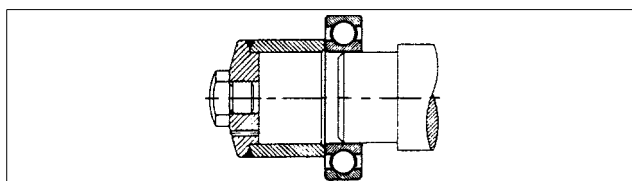

Use assembly tools

G0690411

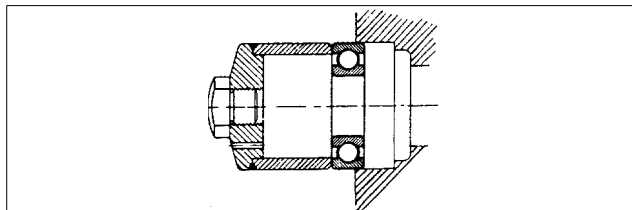

Use assembly tool

G0602411

Angular contact ball bearings

Always fit single-row angular contact ball bearings with the stamped side of the inner race facing the axial load.

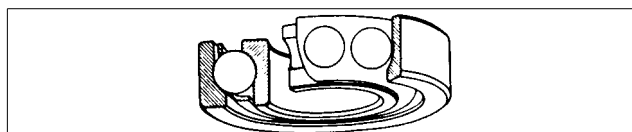

Angular contact bearing must be assembled correctly

G0587211

5.6.3 Friction coupling

If the separator does not attain full speed within about two minutes, the friction elements or the coupling may be worn or greasy. The friction elements must then be replaced with new ones or carefully cleaned from grease.

Before the friction coupling is assembled, examine all parts thoroughly for wear and corrosion.

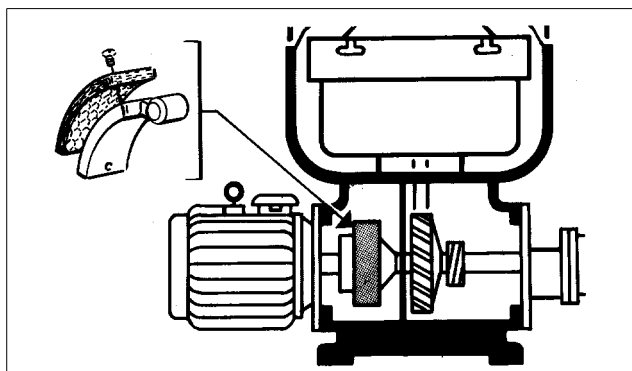

Friction coupling

G0693211

5.6.4 Shutdowns

If the separator is shut down for a period of time, the following must be carried out:

- Remove the bowl, according to instructions in chapter “6 Dismantling/Assembly” on page 77.

NOTE

The bowl must not be left on the spindle during standstill for more than one week.

Vibration in foundations can be transmitted to the bowl and produce one-sided loading of the bearings.

The resultant indentations in the ball bearing races can cause premature bearing failure.

- Protect cleaned carbon steel parts against corrosion by oiling. Separator parts that are not assembled after cleaning must be wiped and protected against dust and dirt.
- The O-rings should be removed.
- If the separator has been shut down for more than 12 months, a Major Service (MS) should be carried out.

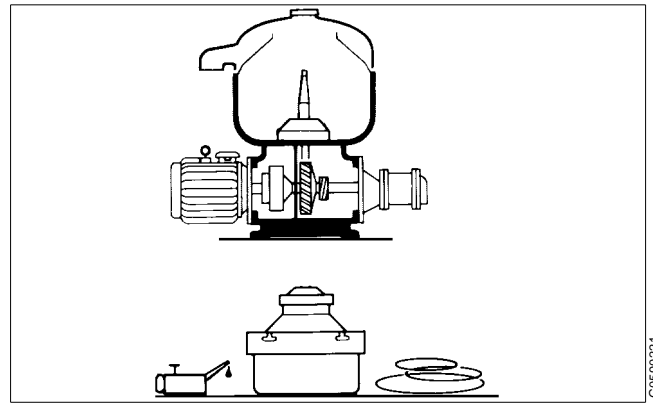

Preparation for shutdown

G0590221

5.7 Lifting instructions

For lifting parts and assemblies of parts use lifting slings, working load limit (WLL): 300 kg.

Lifting the separator

1. Remove the cap nut on the hinged bolt.
2. Remove the separator bowl.
3. Assemble the lifting eye on hinged bolts (the screws must be tightened with spanner).
4. Attach endless slings or cables to the lifting eyes.
5. Lift and handle with care.

NOTE

Remove the separator bowl before lifting to prevent bearings to be damaged.



WARNING

Crush hazards

A dropped separator can cause accidents resulting in serious injury to persons and damage to equipment.

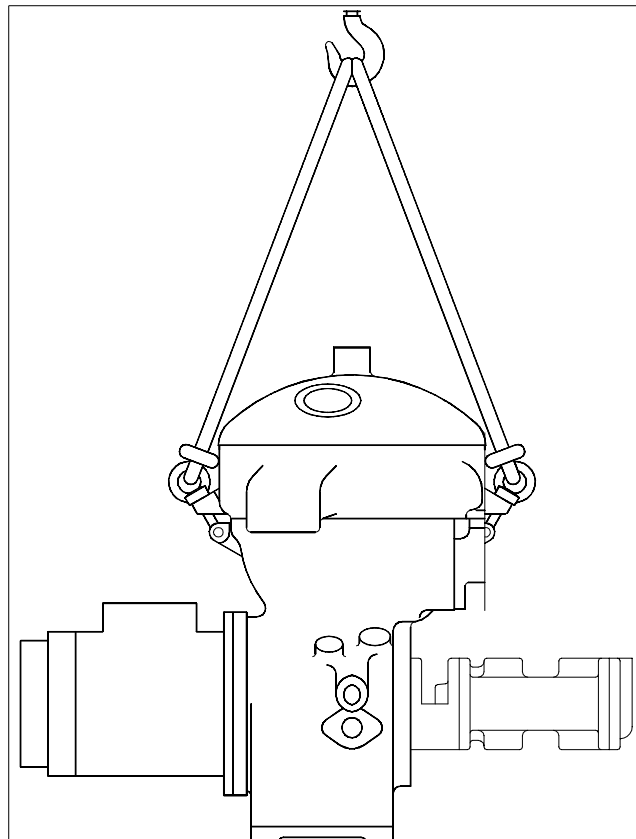

Do not lift the separator in any other way

6 *Dismantling/Assembly*

Contents

6.1 General	78
6.1.1 References to check points	78
6.1.2 Tools	78
6.2 Dismantling	79
6.2.1 Bowl	79
6.2.2 Vertical driving device	83
6.2.3 Horizontal driving device	87
6.3 Assembly	89
6.3.1 Vertical driving device	89
6.3.2 Horizontal driving device	90
6.3.3 Bowl	94
6.4 Feed and discharge pumps	97
6.4.1 Exchange of shear pin coupling	98
6.5 Oil filling	102
6.6 Brake	103
6.6.1 Checking of brake plug	103
6.7 Frame feet	104
6.7.1 Mounting of new frame feet	104

6.1 General

The parts must be handled carefully. Don't place parts directly on the floor, but on a clean rubber mat, fibreboard or a suitable pallet.

6.1.1 References to check points

In the text you will find references to the check point instructions in Chapter 5. The references appear in the text as in the following example:

✓ Check point

“5.3.4 Disc stack pressure” on page 56.

In this example, look up check point “5.3.4 Disc stack pressure” on page 56 for further instructions.

6.1.2 Tools

Special tools from the tool kit shall be used for dismantling and assembly. The special tools are specified in the Spare Parts Catalogue.

NOTE

For lifting parts and assemblies of parts use lifting slings, working load limit (WLL): 300 kg

6.2 Dismantling

To avoid accidental start, switch off and lock power supply.



DANGER

Entrapment hazards

Make sure that rotating parts have come to a **complete standstill** before starting **any** dismantling work.

The revolution counter and the motor fan indicates if separator parts are rotating or not.



S0051011

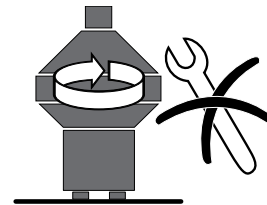

S0051111

6.2.1 Bowl

1. Be sure the bowl has stopped rotating.

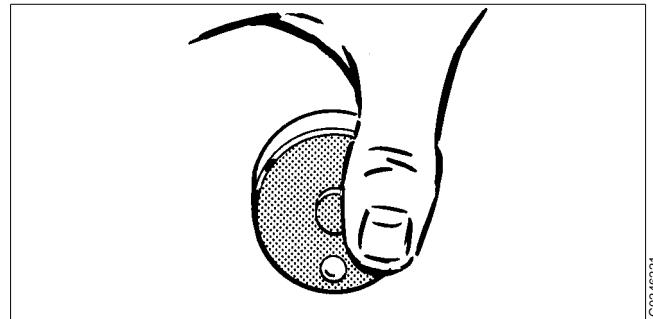

G0246221

2. Loosen the clamp bolts and open the collecting cover.

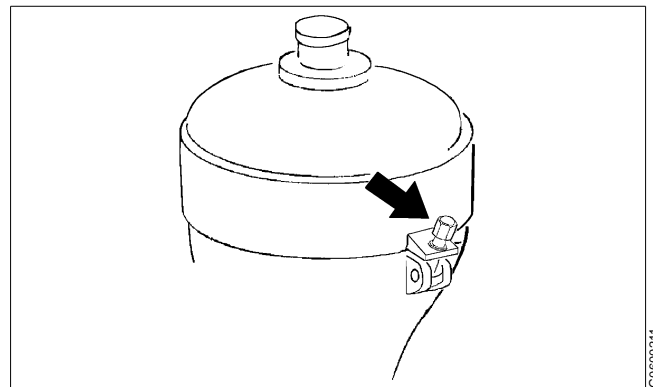

G0600211

3. Tighten both lock screws.

The bowl parts can remain hot for a considerable time after the separator has come to a standstill.

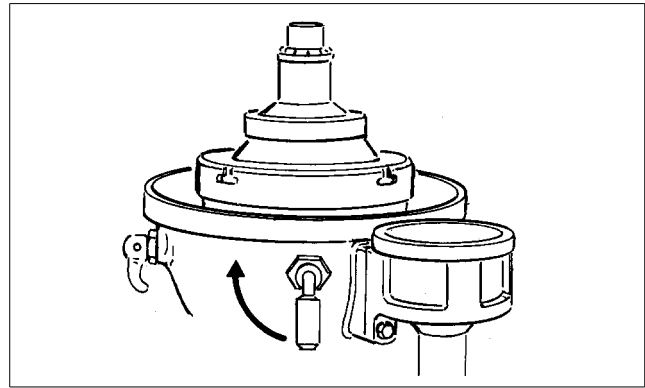

4. Unscrew the small lock ring by using the special tool, "Spanner for small lock ring".

Left hand thread!

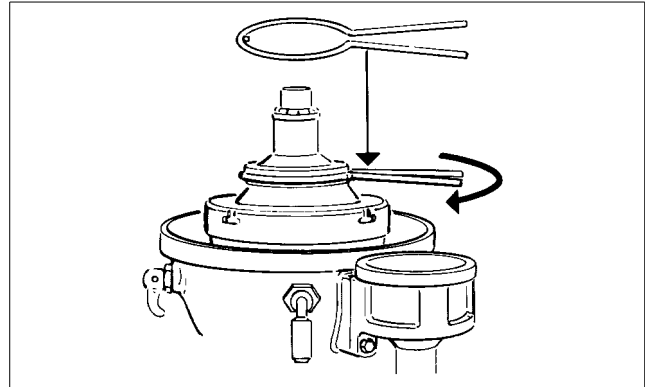

5. Unscrew the large lock ring by using the special tool; "Spanner for lock ring" and a tin hammer.

Left hand thread!

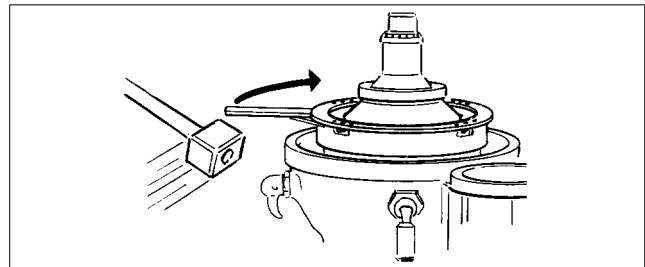

6. Lift off gravity disc/clarifier disc.

NOTE

If the gravity disc has to be replaced owing to changed operating conditions, see “8.1.1 Gravity disc nomogram” on page 120.

Lift out the top disc, disc stack and distributor.



CAUTION

Cut hazard

The discs have sharp edges.

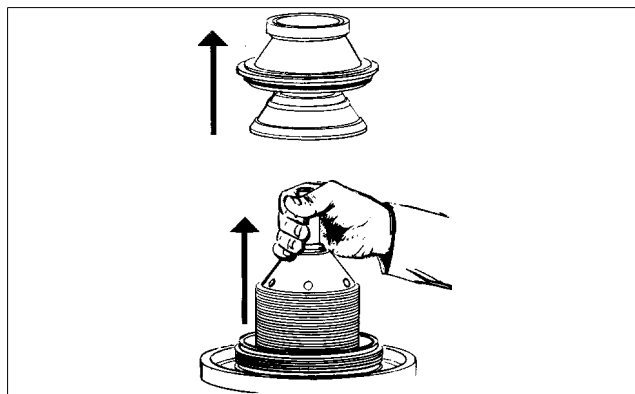

G0595311

7. Unscrew the cap nut (1).
Release the lock screws (2).
Lift out the bowl body using the hand tool (3).

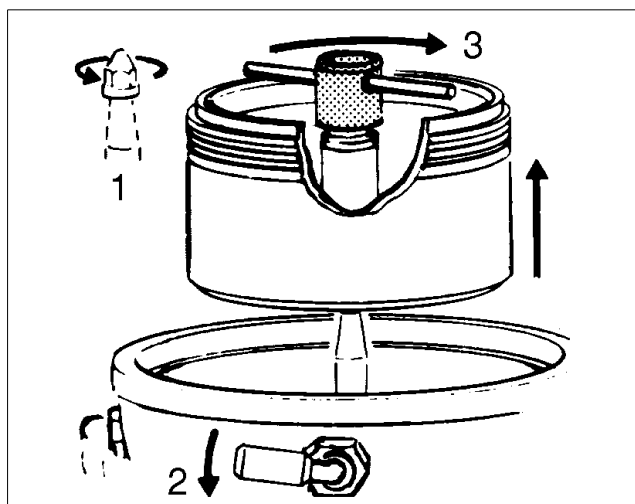

G0595411

- 1 Cap nut
- 2 Lock screws
- 3 Lift bowl body from spindle

8. Disconnect the piping connections.

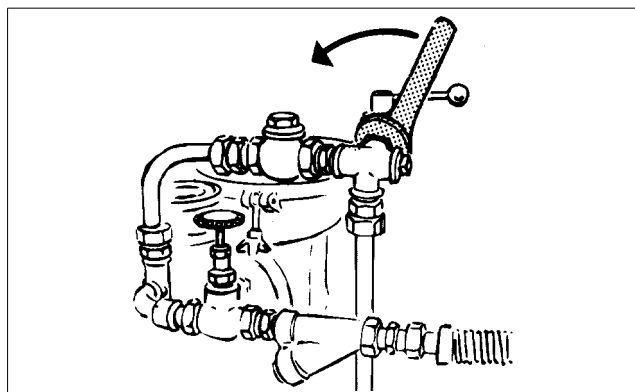

G0595511

9. Remove the outlet parts.

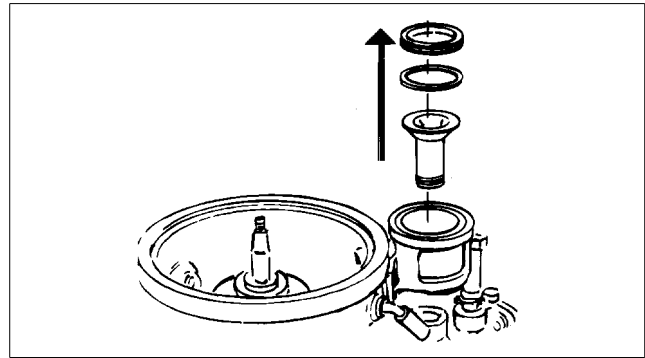

G0595611

Outlet parts

10. Soak and clean all parts thoroughly in suitable cleaning agent, see “5.4 Cleaning” on page 66. Remove O-rings and replace them with spares from the major service kit.

✓ **Check point**

- “5.3.1 Corrosion” on page 52,
- “5.3.2 Erosion” on page 54,
- “5.3.3 Cracks” on page 55.

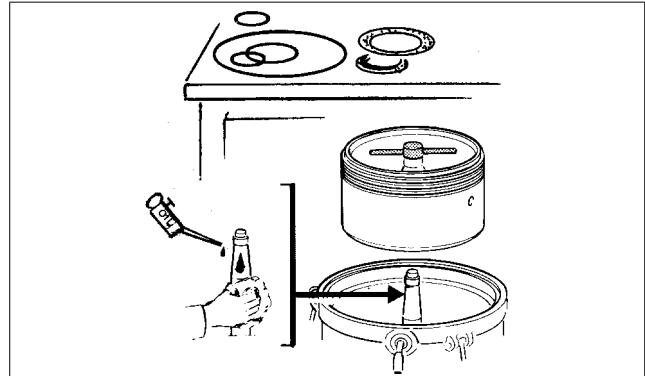

G0590911

Clean the parts

6.2.2 Vertical driving device

Remove the outlet housings, feed and discharge pumps and raise the collecting cover. Remove also the separator bowl.

Before dismantling, in the case of 8000 hours service, or if the separator vibrates while running:

✓ Check point

“5.3.6 Radial wobble of bowl spindle” on page 58.

1. Remove the pump assembly. Inspect the bushings and the wear of seals.

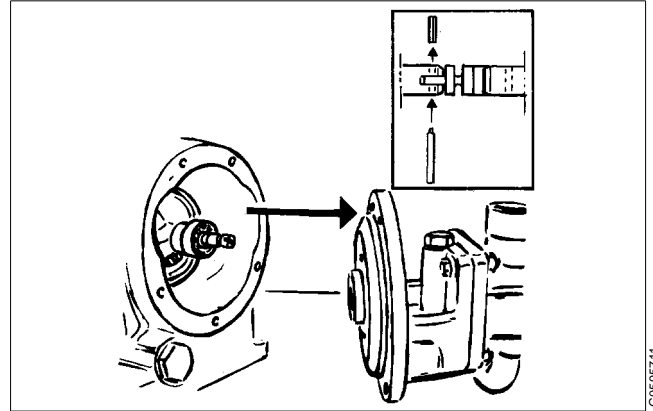

G0595711

2. Loosen the screw for the revolution counter and pull out the revolution counter.

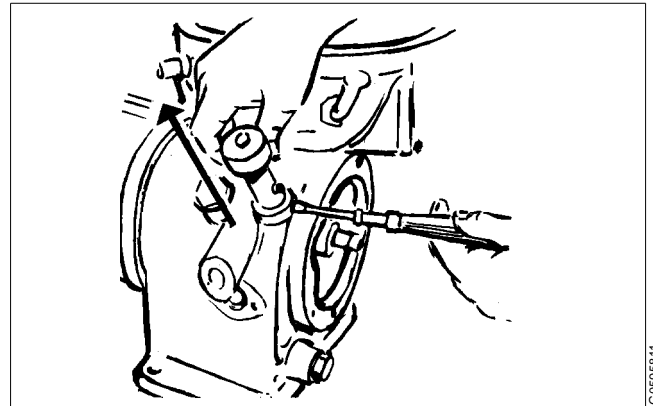

G0595811

3. Force out the conical pin, using a tin hammer as a holder-on for the worm wheel shaft.

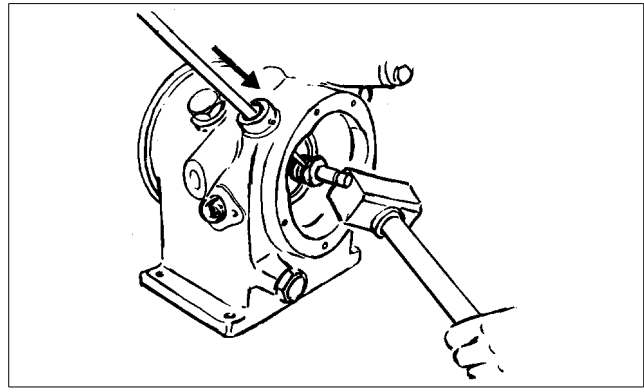

4. Use the puller-tool to first pull off the bearing and then the worm wheel.

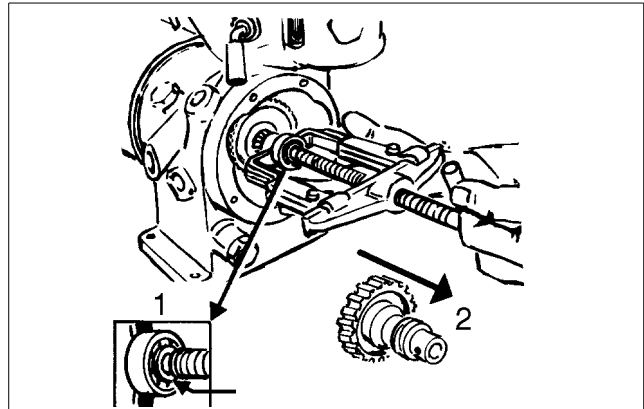

5. Loosen the top bearing holder.

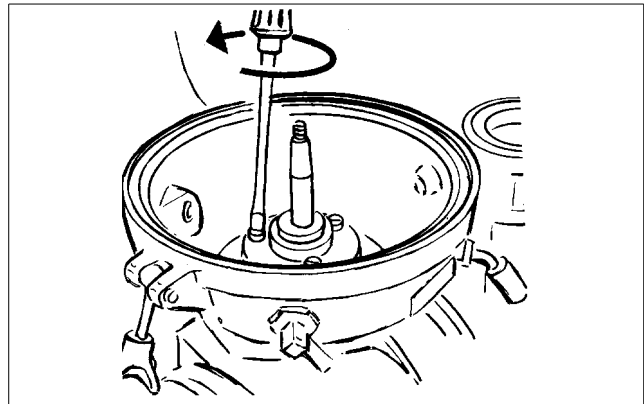

6. Fit the cap nut to the spindle top and lift the spindle.

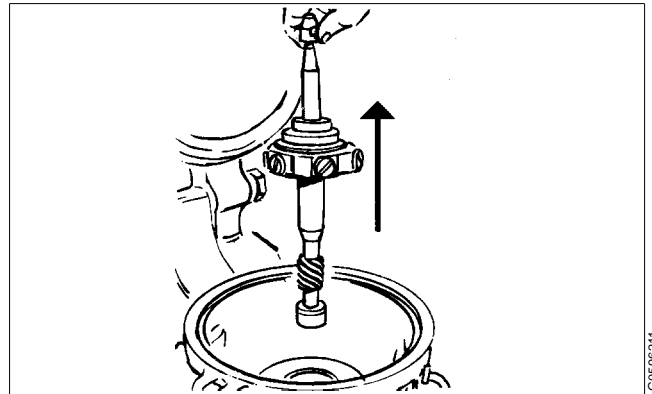

G0596211

7. Use the puller-tool to remove the bottom bearing from the spindle.

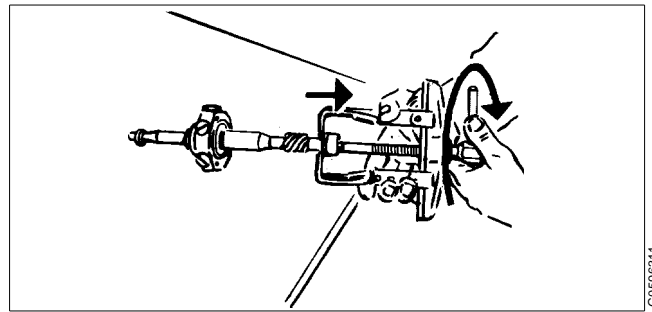

G0596311

8. Loosen and inspect the buffer springs.

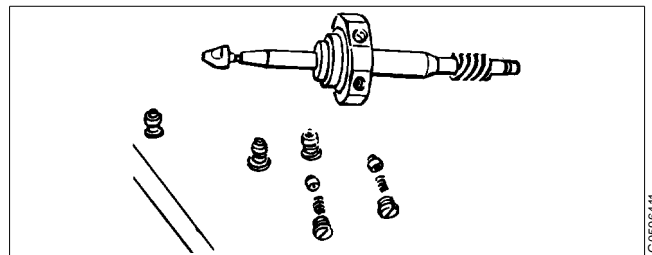

G0596411

9. Pull off the upper ball bearing (together with sleeve).

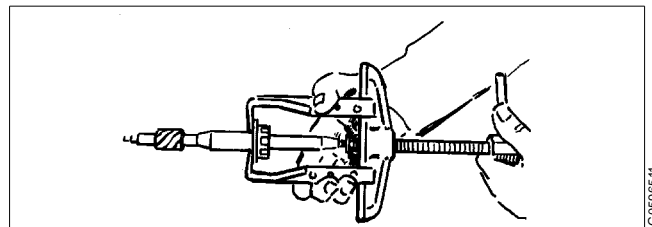

G0596511

NOTE

Always discard a used bearing.

10. Every 3 years: clean the oil sump.

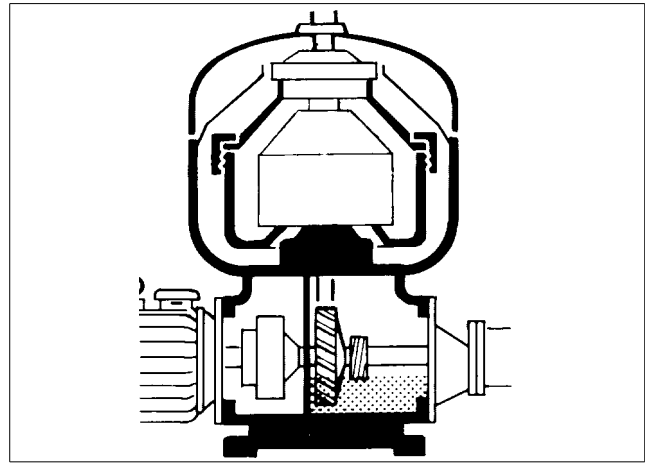

11. Clean all dismantled parts thoroughly in a degreasing agent and check for damage and corrosion.

✓ **Check point**

“5.3.1 Corrosion” on page 52.

Replace all parts supplied in the spare parts kit.

6.2.3 Horizontal driving device

1. Remove the motor.

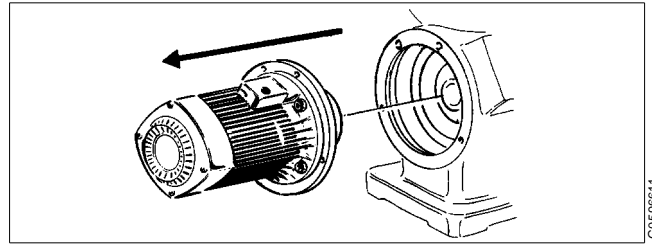

G0596611

2. Renew the pads on the friction blocks.

When refitting the blocks make sure the arrow on each block points in the same direction of rotation. See the arrow on the frame.

Secure the blocks with washer and split pin.
If the friction elements are worn: fit new ones.

Replace all friction elements even if only one is worn.

If the friction elements are only greasy:
clean the friction elements and the inside of the coupling drum with a degreasing agent.

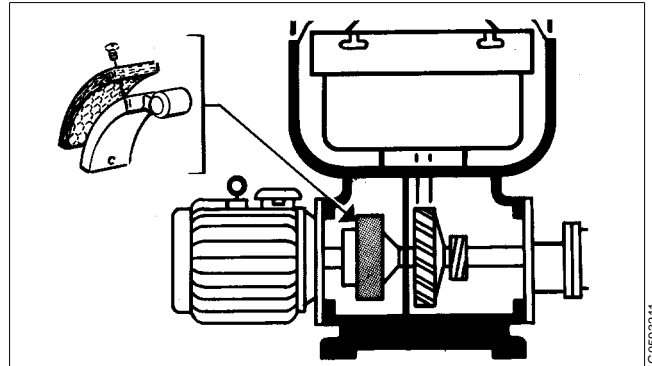

G0693211

3. Loosen the three screws holding the sealing washer. Use a hexagon key.

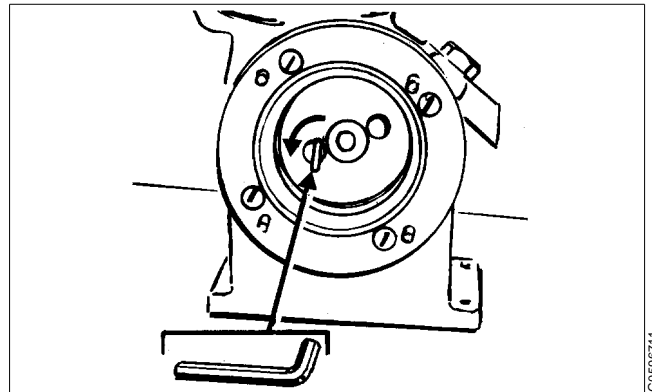

G0596711

4. Remove the worm wheel shaft.

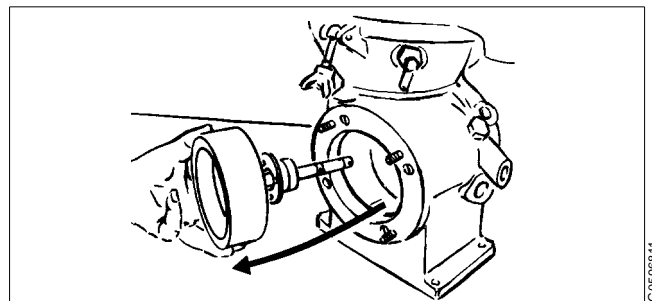

G0596611

5. Use the puller tool to pull off the sealing washer. Protect end of worm wheel shaft with a washer.

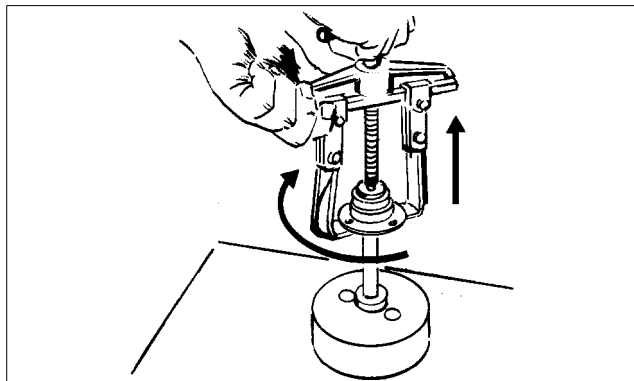

6. To replace coupling drum or worm wheel shaft force out the spring pin and gently knock out the shaft.

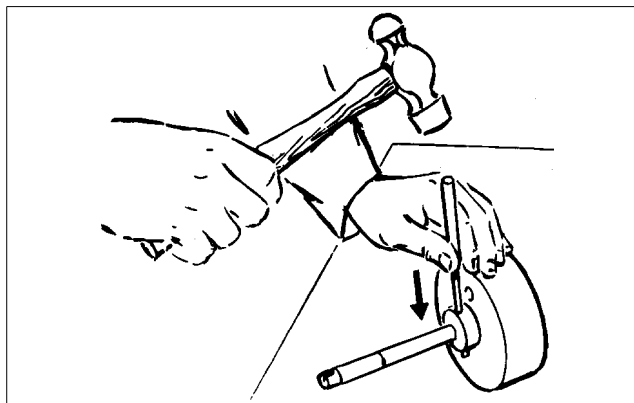

7. Knock out the horizontal spindle.

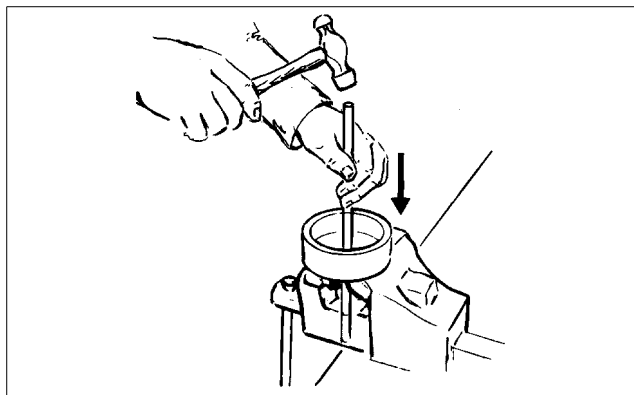

6.3 Assembly

Clean all parts in a degreasing agent and replace parts supplied in the Spare parts kits.

✓ Check point

- “5.3.1 Corrosion” on page 52,
- “5.3.2 Erosion” on page 54,
- “5.3.3 Cracks” on page 55,
- “5.3.11 Top bearing springs” on page 62,
- “5.3.12 Ball bearing housing” on page 62,
- “5.3.13 Worm wheel and worm; wear of teeth” on page 63.

6.3.1 Vertical driving device

Before assembling the bowl spindle, make sure the relevant checks have been carried out.

Wipe off and oil the bearing seat before fitting the ball bearing.

Inspect the tapered end of the bowl spindle and assemble ball bearings.

Heat the new ball bearings in oil to maximum 125 °C.

NOTE

Always fit new bearings.

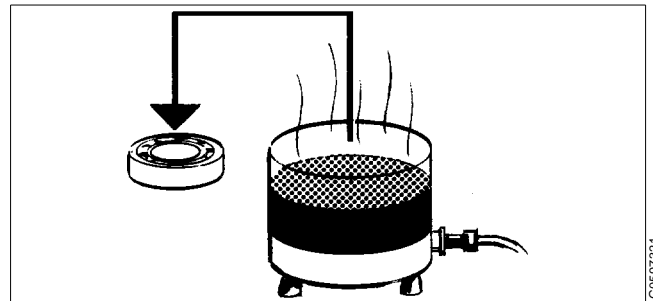

G0597321

1. Fit the bearing onto the shaft.



CAUTION

Burn hazards

Use protective gloves when handling the heated bearings.

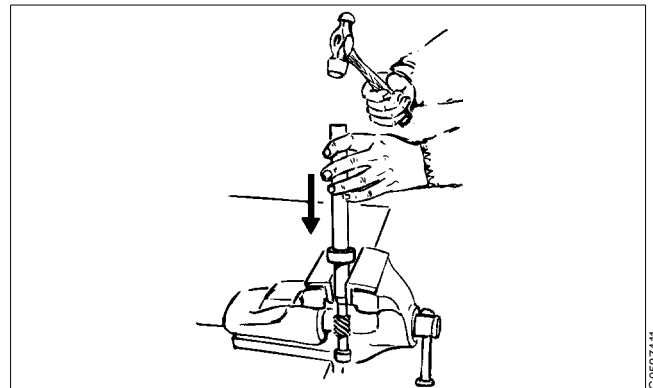

G0597411

- Lower the spindle into position.
Apply some Loctite 242 onto the threads of the screw.
Check for impact marks on the spindle cone and in the bowl body nave.

✓ **Check point**
“5.3.7 Bowl spindle cone and bowl body nave” on page 59.

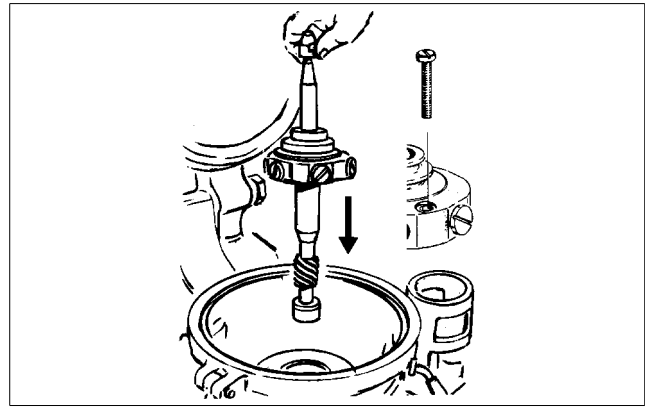

G0597511

6.3.2 Horizontal driving device

- Clean the worm wheel shaft and the inner surface of the worm wheel nave thoroughly.
Make sure seal ring in sealing washer is turned in the right direction.

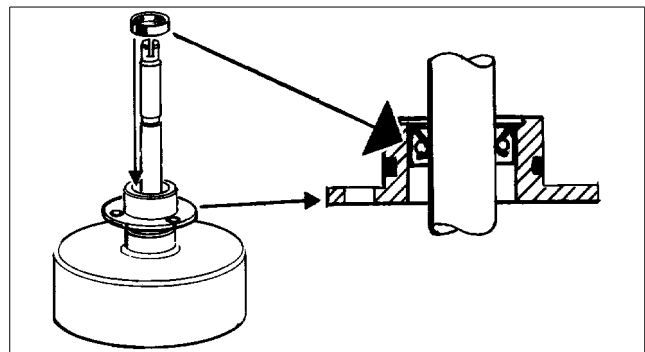

G0597611

- Force bearing onto shaft, but stop when sealing washer is approx. 10 mm from bottom position.

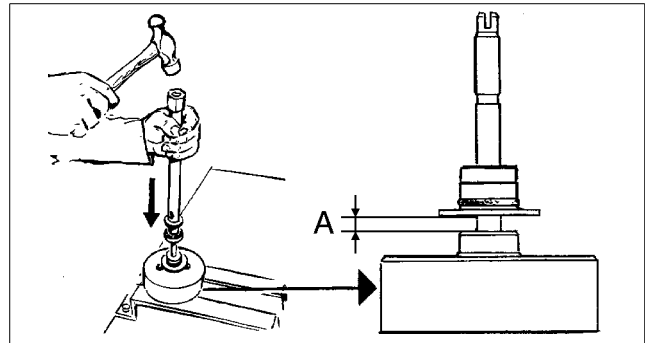

G0597711

Stop forcing bearing when $A=10\text{ mm}$

3. Push the worm wheel into its position on the shaft on top of the bearing.

Knock with a brass sleeve on end of wheel.
Observe holes for spring pin.

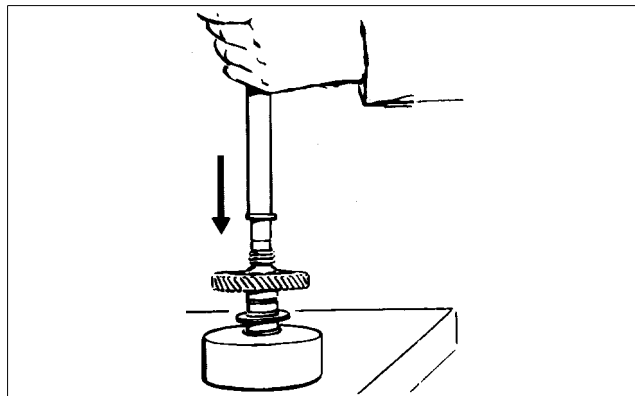

G0598011

Count the number of teeth! See Chapter
“8 Technical Reference” on page 115.



DANGER

Disintegration hazard

When replacing the gear, always make sure that the new worm wheel and worm have the same number of teeth as the old ones.

4. Check with the conical pin to get the larger side of holes in same direction, when holes coincide, mark the parts to facilitate the fitting. Remove worm wheel from shaft.

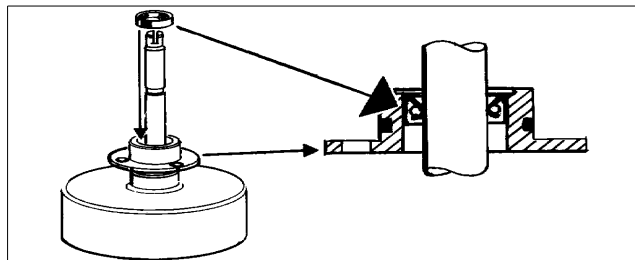

G0597611

5. Clean the ball bearing housing in the frame and oil the outer race of the ball bearing. Force the worm wheel shaft into its position in the frame, so that the ball bearing enters correctly into its seat.

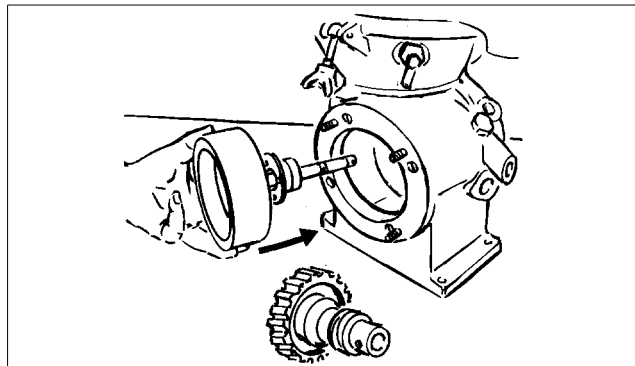

G0598111

6. Tighten screws of sealing washer.

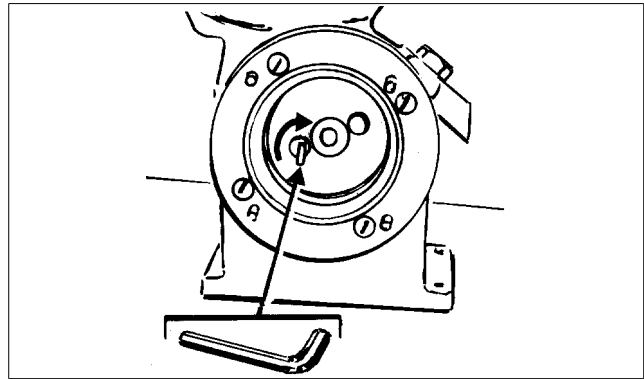

G0598211

7. Fit the worm wheel and knock conical pin into holes.

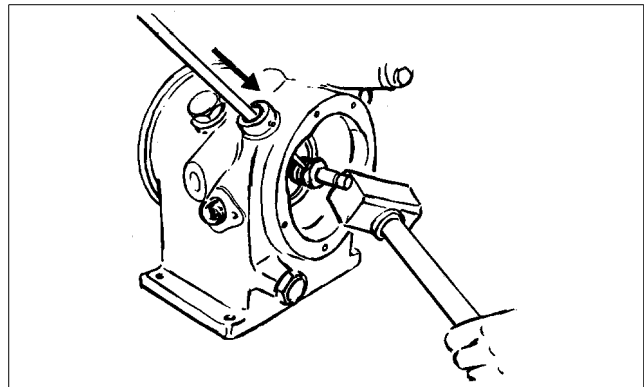

G0598311

8. Knock the bearing into position with the mounting tool and a hammer.

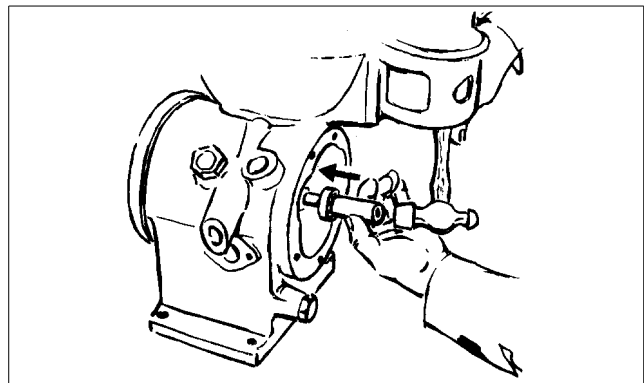

G0598411

9. Fit the revolution counter.
Lock it with the lock screw.

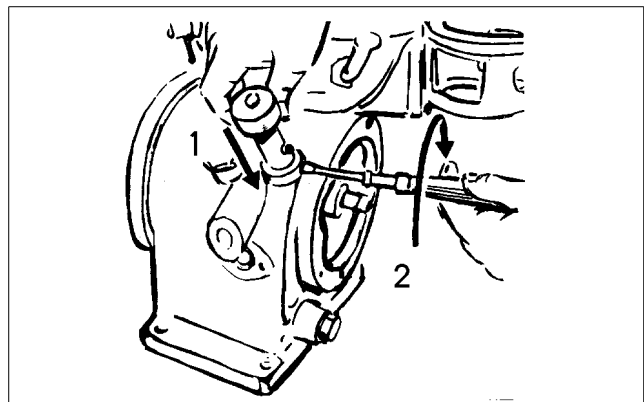

G0598511

10. Fit pump and shear pin coupling.

See “6.4.1 Exchange of shear pin coupling” on page 98.

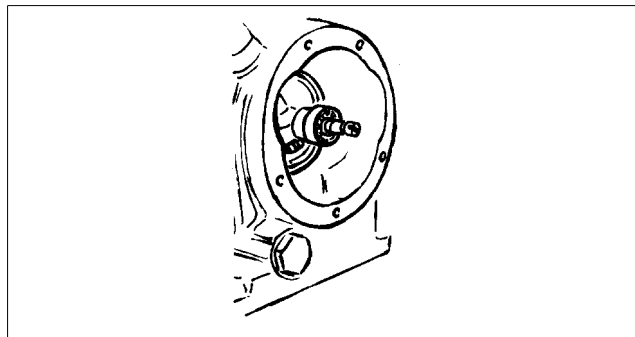

G0598611

11. If the coupling disc has been loosened without first marking its position on the motor shaft, the correct position for position of coupling disc must be determined again.

✓ **Check point**

“5.3.8 Coupling disc of motor” on page 60.

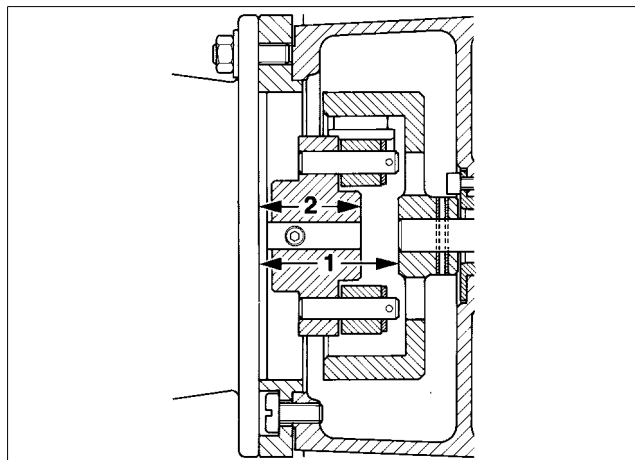

G0593511

12. Fit the motor.



DANGER

Disintegration hazards

When power cables have been connected, always check direction of rotation. If incorrect, vital rotating parts could unscrew causing disintegration of the machine.

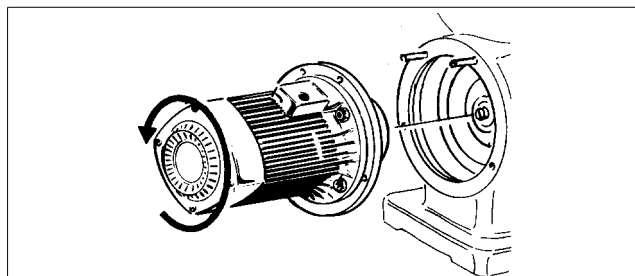

G0598711

6.3.3 Bowl

Make sure that the check points are carried out before and during assembly of the separator bowl.

✓ Check points

“5.3.7 Bowl spindle cone and bowl body nave” on page 59.

1. Wipe off spindle top and nave bore in the bowl body. Apply a few drops of oil onto the taper, smear it over the surface and wipe it off with a clean cloth.

Fit the bowl body on the spindle. Be careful not to damage the spindle cone.

Screw cap nut onto the spindle. Tighten firmly.

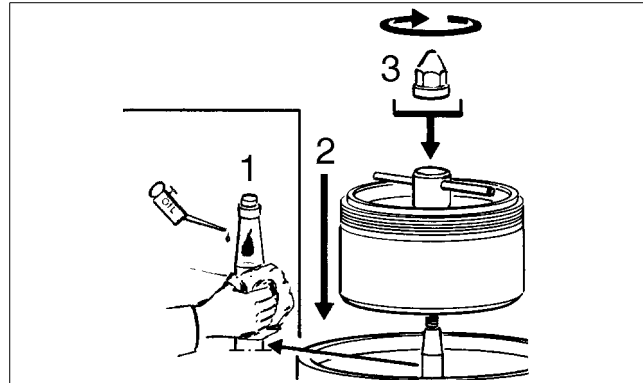

G0598811

2. Before assembling the bowl discs, check the threads of the bowl hood and bowl body.

✓ Check point

“5.3.5 Lock ring; wear and damage” on page 56.

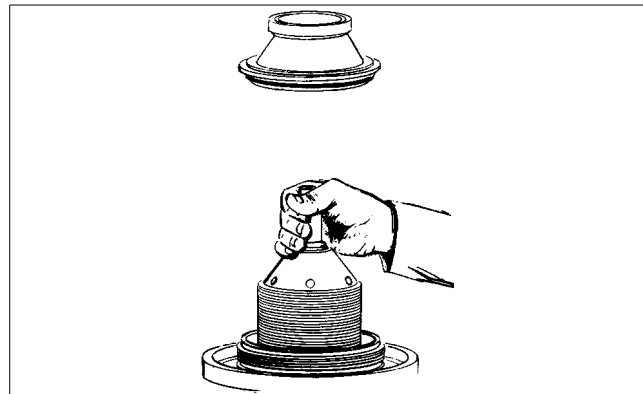

G0595331

3. Fit bowl hood into position. Make sure guides are correctly located.

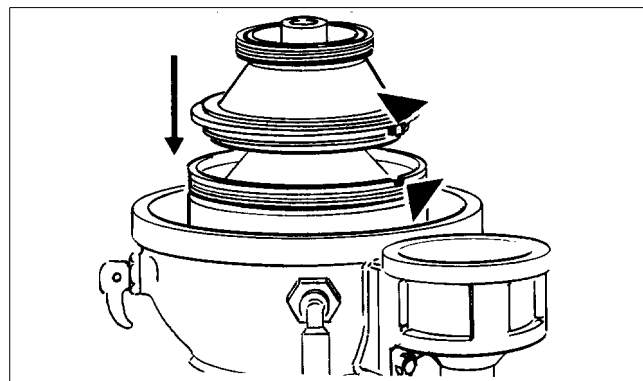

G0599011

4. Degrease lock ring threads, contact and locating faces (see arrows above). Apply Molykote 1000 paste to the threads and faces stated.

Brush in the paste according to the manufacturer's direction.

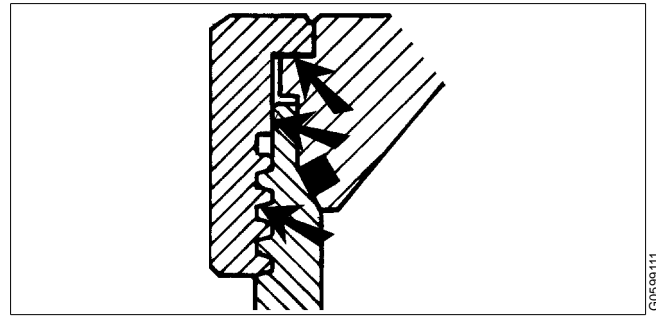

G0599111

5. Secure the bowl from rotating. Screw in **both** lock screws.

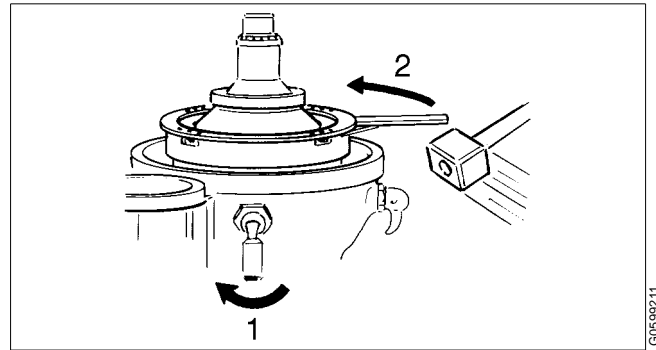

G0599211

6. Tighten lock ring counter-clockwise (left-hand thread) until bowl hood lies tightly against bowl body (in a new bowl marks will now be in line with each other - see above).

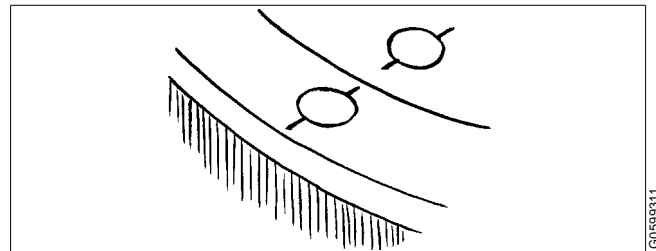

G0599311

Left-hand thread!



WARNING

Disintegration hazard

The assembly mark on the bowl hood must never pass the mark on the bowl body by more than 25° (or 25 mm).

✓ Check point

"5.3.4 Disc stack pressure" on page 56.

7. Release both lock screws and tighten clamp bolts.

NOTE

The two lock screws must be fully released to prevent risk for damage to bowl body.

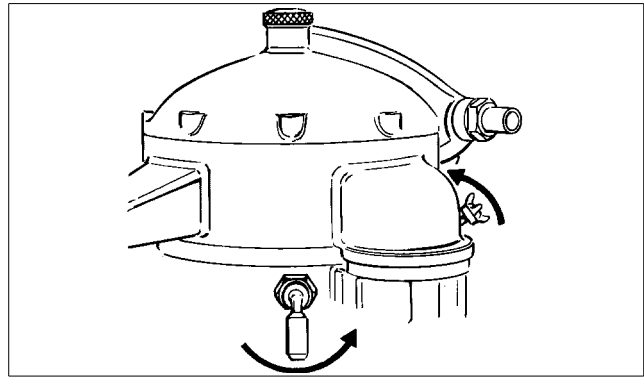

8. Fit the connecting hoses if they have been removed. Make sure to fit their gasket rings.

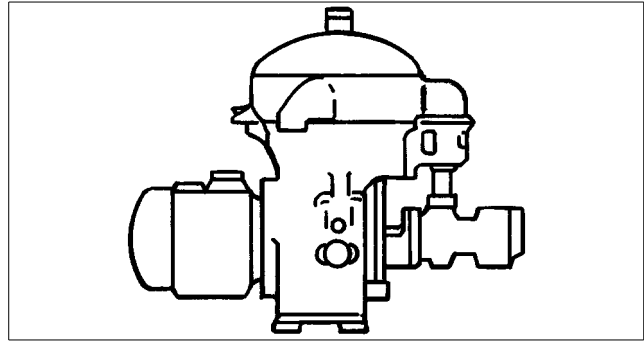

6.4 Feed and discharge pumps

1. Relief/safety valve:
Examine valve cone and valve seat.
2. Bushings:
Exchange the bushings if they are scratched or there is a play between shaft and bushing.
3. Wearing seals:
Replace the seals if the surface is rough cracked or dented by the impeller.

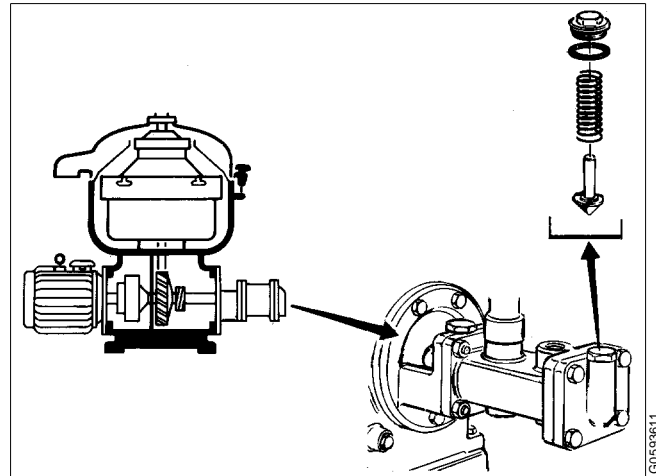

4. Lipseal rings:
Replace the rings at the annual overhaul. **Important!** Turn the rings the right way round.
5. Shear pin coupling:
See "6.4.1 Exchange of shear pin coupling" on page 98.
6. Impeller shaft:
Check the groove in the impeller shaft.
7. Disengagement:

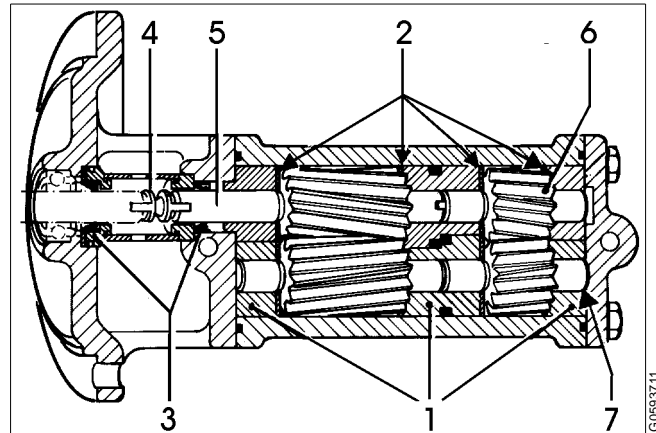

The feed pump can be disengaged by turning the impeller (6), thereby placing the driving blade of the impeller in the recess of the shield.

1. *Bushings*
2. *Wearing seals*
3. *Lipseal rings*
4. *Shear pin coupling*
5. *Impeller shaft*
6. *Disengagement*
7. *Axial play*

8. Axial play:

The total axial play (1) must be 0,1 - 0,3 mm. If the play is too large even though the wearing seals have been renewed, it can be compensated by adding a brass leaf liner.

Insert the liner at (2). If the play is too small, grind off the bearing holder (3).

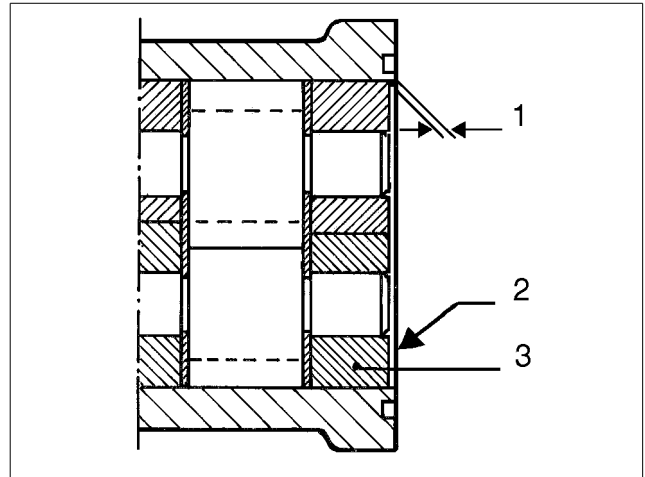

Axial play 0,1 - 0,3 mm

6.4.1 Exchange of shear pin coupling

1. Remove the pipe connections of the pump. Screw off the lock ring of the sight glass. Remove the upper gasket and the sight glass.

Remove the screws of the control housing.

Lift the control housing with the lower gasket and the connecting piece.

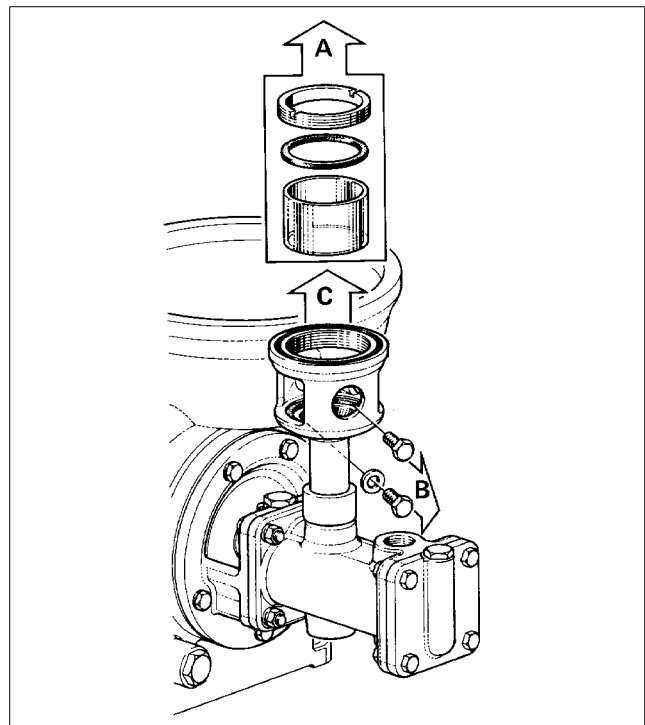

- Remove the sleeve halves over the shear pin coupling.
Remove the pump housing with parts.

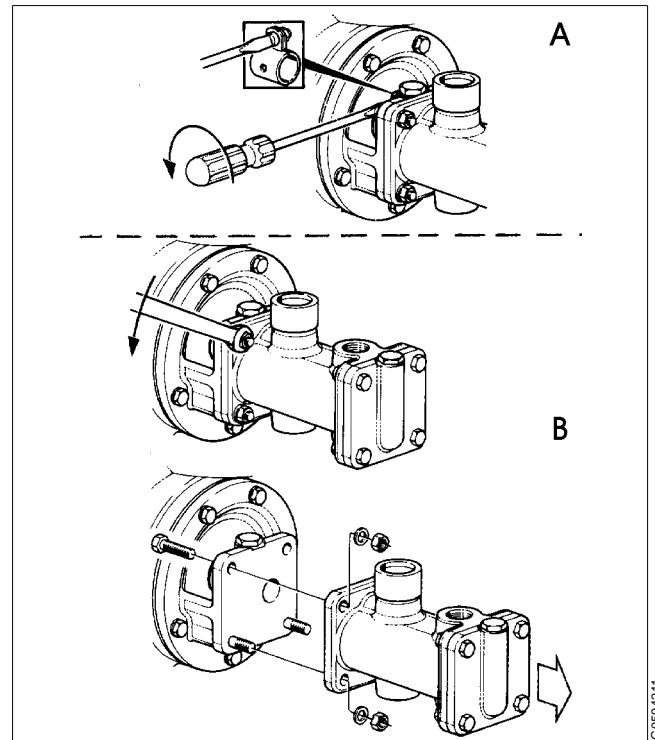

G0594211

- Drive out the tubular pin (a) from the worm wheel shaft. Use a counterstop.
Remove the sleeve (b) from the bearing shield.

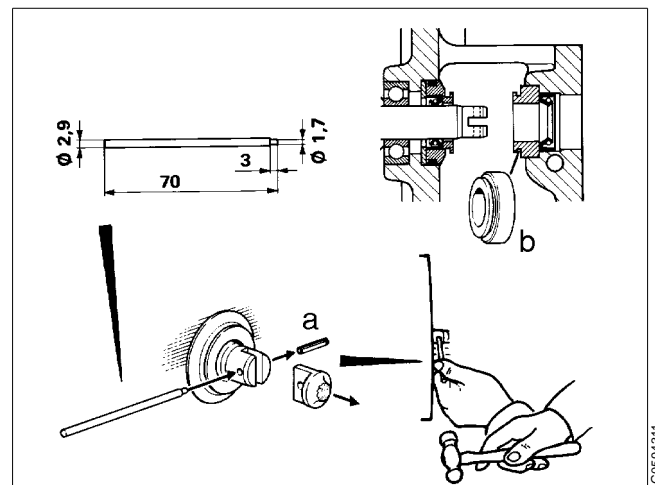

G0594311

- If the tubular pin in the impeller shaft is broken: drive out the tubular pin. Use a counterstop.

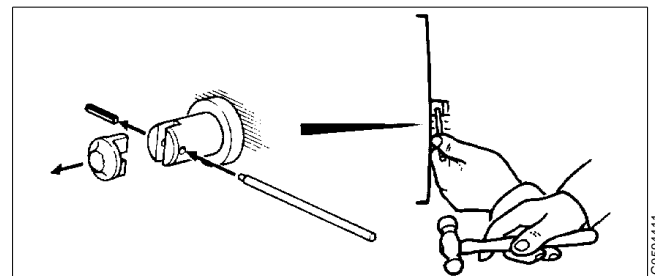

G0594411

5. Check that the lipseal ring (c) is faultless.

Should this not be the case, fit a new ring, turned the right way.

Fit the new shear pin coupling (d) in the worm wheel shaft together with the sleeve (b). Drive the tubular pin (a) into its position. Use a counterstop.

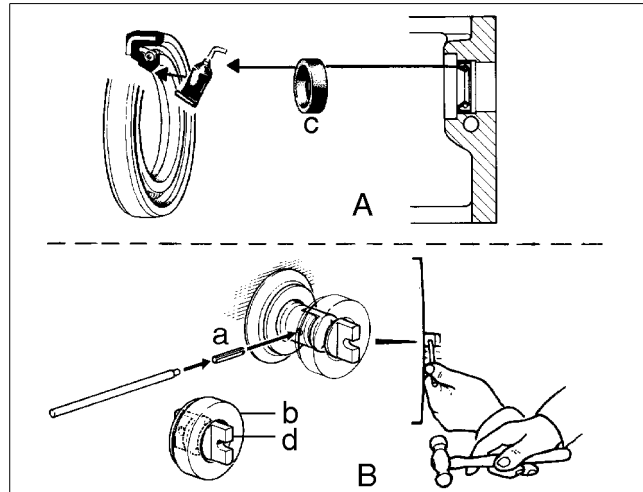

G0694511

6. Check that the impeller shaft can be revolved by hand.

Should this not be the case: dismantle the pump and check the parts. See "6.4.1 Exchange of shear pin coupling" on page 98.

Drive in a new tubular pin if the old one is broken. Use a counterstop.

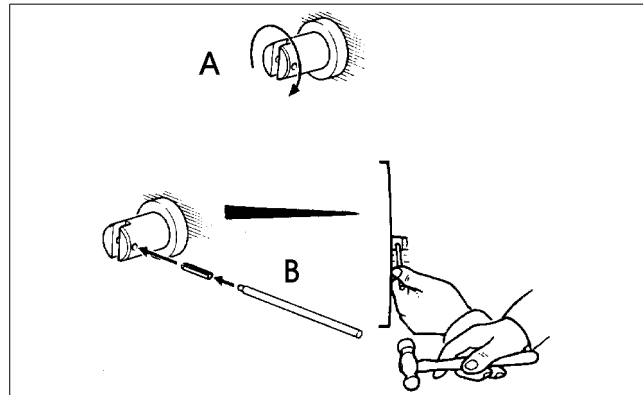

G0694611

- Fit the pump housing with parts. Be careful not to damage the lipseal ring.

Fit the sleeve halves over the shear pin coupling.

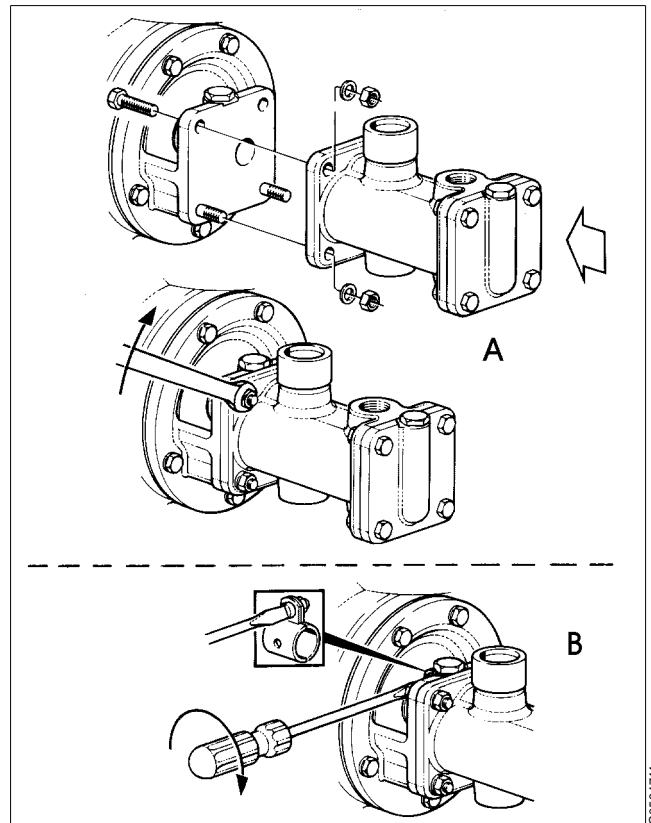

G0594711

- Put down the control housing with connecting piece and the lower gasket.

Tighten the screws.

Fit the sight glass and the upper gasket. Screw on the lock ring.

Fasten the pipe connections of the pump.

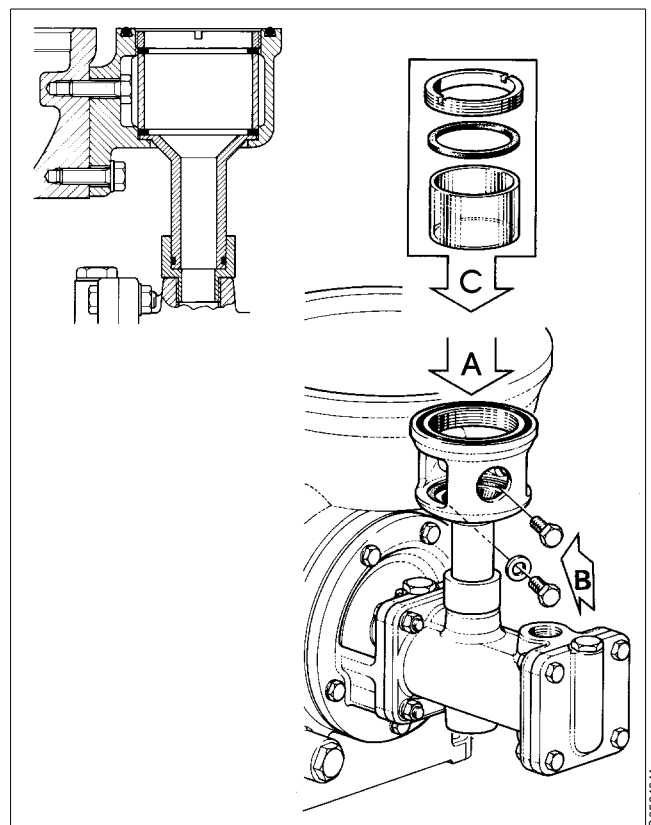

G0594811

6.5 Oil filling

NOTE

Before adding or renewing lubricating oil in the worm gear housing, the information concerning different oil groups, handling of oils, oil change intervals etc. given in chapter "8 Technical Reference" on page 115 must be well known.

1. Place a collecting tray under the drain hole, remove the drain plug to drain off the oil.



CAUTION

Burn hazards

Lubricating oil and various machine surfaces can be sufficiently hot to cause burns.

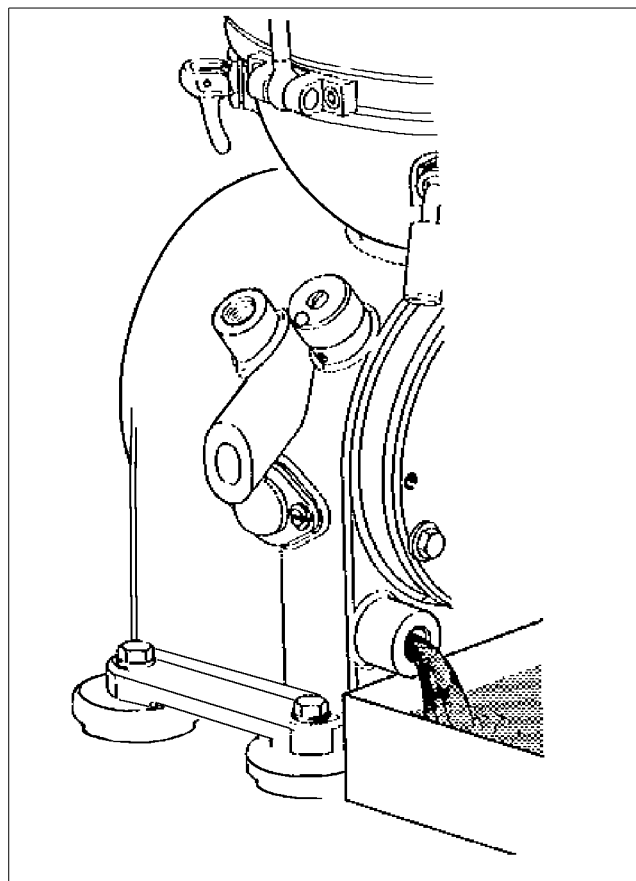

G0602611

2. Fill new oil in the worm gear housing. The oil level should be slightly above middle of the sight glass. For lubricating oil volume see chapter "8 Technical Reference" on page 115.

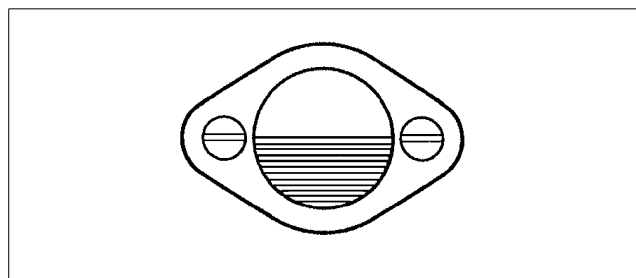

G0602711

6.6 Brake

6.6.1 Checking of brake plug

A worn or oily brake plug will lengthen the stopping time. Remove the bracket with the brake. Examine the friction element.

- Replace the plug when the friction material is worn. If the thickness **A** of the friction material is less than **0,5 mm** the brake plug need to be replaced.
- If the friction element is oily: clean the brake plug and the outside surface of the bowl body with a suitable degreasing agent.

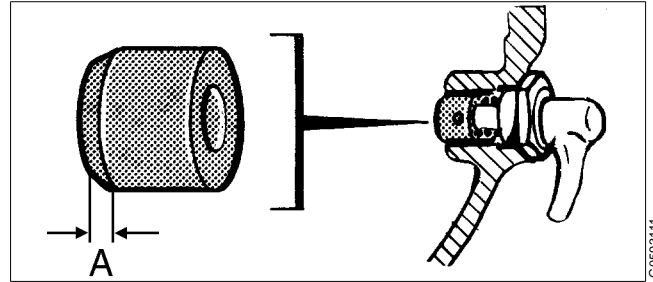

Maximum wear of brake plug when $A=0,5\text{ mm}$

Checking the brake

After the brake assembly has been fitted, release the brake and rotate the bowl slowly by hand. If a scraping noise is heard, the friction element is probably touching the bowl surface.

For normal stopping time see “8.1 Technical data” on page 116.

6.7 Frame feet

When replacing the frame feet, the separator must be lifted.

See “5.7 Lifting instructions” on page 76.

NOTE

Always remove the bowl before lifting the separator.

When lifting and moving the separator, follow normal safety precautions for lifting large heavy objects.

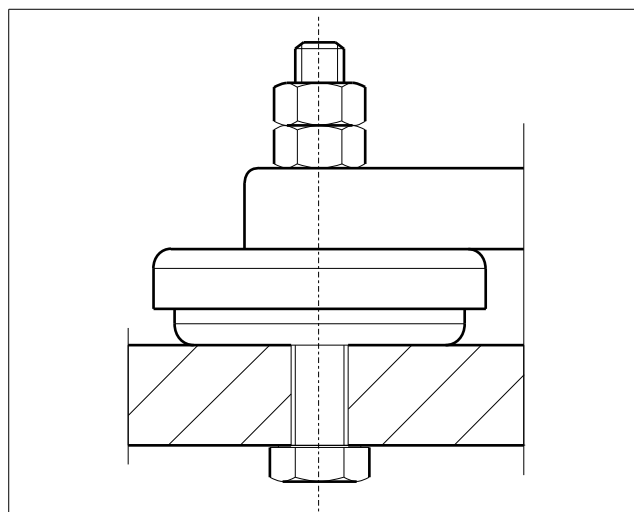

Frame foot with vibration damping

6.7.1 Mounting of new frame feet

1. Remove the existing frame feet.
2. Mount the new feet. Tightening torque 16 Nm. Secure the bolt with the lock-nut.
3. Place the separator in its original position and assemble the separator.
4. Remove the two eye bolts used for lifting.

7 *Trouble-tracing*

Contents

7.1	Trouble tracing procedure	106
7.2	MAB mechanical function	106
7.2.1	The separator does not start	106
7.2.2	Start-up time too long	106
7.2.3	Starting power too low	107
7.2.4	Starting power too high	107
7.2.5	Separator vibrates excessively during starting sequence	108
7.2.6	Separator vibrates excessively during normal running	108
7.2.7	Smell	109
7.2.8	Noise	109
7.2.9	Speed too high	109
7.2.10	Speed too low	110
7.2.11	Stopping time too long	110
7.2.12	Water in oil sump	110
7.2.13	Liquid flows through bowl casing drain	111
7.3	Purification faults	112
7.3.1	Unsatisfactory separation result	112
7.3.2	Outgoing water contaminated by oil	112
7.3.3	Broken water seal	113
7.4	Clarification faults	114
7.4.1	Unsatisfactory separation result	114
7.4.2	Oil discharge through water outlet	114

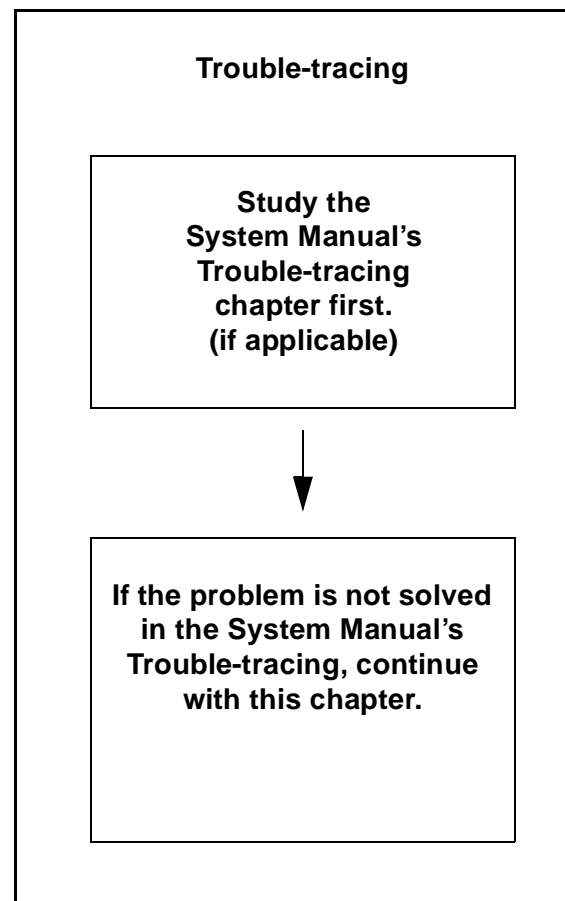

7.1 Trouble tracing procedure

This chapter applies to trouble-tracing concerning functions of the separator only. It does not include the other equipment in your processing system.

Always start with trouble-tracing instructions in the System Manual, and if required, continue with the instructions below. If the problem still is not solved, contact your Alfa Laval representative.

7.2 MAB mechanical function

7.2.1 The separator does not start

Possible cause	Action
No power supply to motor.	Check power supply.
Bowl lock screws stops rotation.	Release lock screws.

7.2.2 Start-up time too long

Possible cause	Action
Brake applied.	Release brake.
Friction pads worn or oily.	Fit new friction pads.
Motor failure.	Repair.
Incorrect power supply (50 Hz instead of 60 Hz).	Use correct power supply. See machine plate.
Bearings damaged or worn.	Install new bearings.

7.2.3 Starting power too low

Possible cause	Action
Motor failure.	Repair the motor.
Friction pads worn.	Fit new friction pads.
Friction pads oily.	Fit new friction pads.

7.2.4 Starting power too high

Possible cause	Action
Bowl lock screws stops rotation.	Release lock screws.
Brake is on.	Release brake.
Motor failure.	Repair the motor.
Gear worn out.	Replace worm wheel and worm.
Bearing damaged or worn.	Install new bearings.
Incorrect transmission (50 Hz gear and 60 Hz power supply).	 DANGER: Disintegration hazard STOP immediately! Install correct transmission. Contact your local Alfa Laval representative. The bowl must be inspected.
Wrong direction of rotation.	STOP. Adjust motor power connection.

7.2.5 Separator vibrates excessively during starting sequence

NOTE Some vibration is normal during starting sequence when the separator passes through its critical speeds.

Possible cause	Action
<p>Bowl out of balance due to:</p> <ul style="list-style-type: none"> poor cleaning incorrect assembly too few discs insufficiently tightened bowl hood bowl assembled with parts from other separators. 	<p>⚠ DANGER: Disintegration hazard</p> <p>STOP immediately! Identify and rectify cause.</p>
<p>Vibration dampers in frame feet worn out.</p> <p>Bowl spindle bent (max. 0,15 mm).</p> <p>Top and/or bottom bearing damaged or worn.</p> <p>Top bearing springs defective.</p>	<p>Fit new vibration dampers.</p> <p>Fit a new bowl spindle.</p> <p>Fit new bearings.</p> <p>Fit new springs.</p>

7.2.6 Separator vibrates excessively during normal running

Possible cause	Action
<p>Uneven sludge deposits in sludge space.</p> <p>Bearings damaged or worn.</p> <p>Vibration-damping rubber washers worn out.</p> <p>Spindle top bearing spring(s) broken.</p>	<p>STOP and clean bowl.</p> <p>Fit new bearings.</p> <p>Fit new frame feet washers every four years.</p> <p>Replace all springs.</p>

7.2.7 Smell

Possible cause	Action
Normal occurrence during start as the (new) friction blocks slip.	None.
Brake is applied.	Release the brake.
Top and/or bottom bearing overheated.	Fit new bearings.

7.2.8 Noise

Possible cause	Action
Oil level in oil sump is too low.	STOP and read oil level and add oil.
Top and/or bottom bearing damaged or worn.	Fit new bearings.
Friction pads worn.	Fit new friction pads.

7.2.9 Speed too high

Possible cause	Action
Incorrect transmission (50 Hz gear running on 60 Hz power supply).	 DANGER: Disintegration hazard STOP immediately! Install correct transmission. Contact your local Alfa Laval representative. The bowl must be inspected.
Frequency of power supply too high.	Check.

7.2.10 Speed too low

Possible cause	Action
Brake is on.	Release the brake.
Friction pads worn or oily.	Fit new friction pads or clean the old ones if they are oily.
Motor failure.	Repair the motor.
Top/bottom bearings damaged or worn.	Fit new bearings.
Bearing overheated/damaged.	Fit new bearings.
Incorrect transmission (60 Hz gear running on 50 Hz current).	Make sure that the gear is intended for 50 Hz power supply.

7.2.11 Stopping time too long

Possible cause	Action
Brake lining worn or oily.	Fit new friction pads or clean the old ones if they are oily.

7.2.12 Water in oil sump

Possible cause	Action
Bowl casing drain obstructed.	Clean. Change oil.
Leakage at top bearing.	Fit a new seal ring and change oil.
Condensation.	Clean the oil sump. Change oil.

7.2.13 Liquid flows through bowl casing drain

Possible cause	Action
Broken water seal.	Stop feed and feed water to create water seal.
Too high throughput	Reduce the feed.
The supply of displacement/sealing water is not sufficient due to clogged strainer, kinked hose or low water pressure.	Straighten the hose or clean the strainer. Make sure the water pressure is 200-600 kPa (2-6 bar).
Seal ring on gravity/clarifier disc defective.	Fit a new seal ring.
Bowl hood seal ring defective.	Fit a new seal ring.
Bowl speed too low.	Make sure current is on and brake is off. Inspect motor and power transmission.

7.3 Purification faults

7.3.1 Unsatisfactory separation result

Possible cause	Action
Gravity disc hole too small.	Use a gravity disc with a larger hole.
Incorrect separating temperature.	Adjust temperature.
Throughput too high.	Reduce throughput.
Sludge space in bowl is filled.	Empty the sludge basket in the bowl.
Disc stack clogged.	Clean the bowl discs.
Bowl speed too low.	See "7.2.10 Speed too low" on page 110.

7.3.2 Outgoing water contaminated by oil

Possible cause	Action
Gravity disc hole too large.	Use a gravity disc with a smaller hole.
Seal ring under the gravity disc defective.	Fit a new seal ring.

7.3.3 Broken water seal

Possible cause	Action
Gravity disc too large.	Use a gravity disc with a smaller hole.
Separation temperature too low.	Increase temperature.
Throughput too high.	Reduce throughput.
Sealing water volume too small.	Supply more water.
Seal ring under gravity disc defective.	Fit a new seal ring.
Disc stack clogged.	Clean the bowl discs.
Bowl speed too low.	Use correct speed. See “7.2.10 Speed too low” on page 110.
Bowl incorrectly assembled.	Examine and make correct.

7.4 Clarification faults

7.4.1 Unsatisfactory separation result

Possible cause	Action
Separating temperature too low.	Adjust.
Throughput too high.	Reduce throughput.
Feed oil contains water.	Re-assemble and operate the separator as a purifier.
Disc stack clogged.	Clean the bowl discs.
Sludge space in bowl filled.	Empty the sludge basket.
Bowl speed too low.	See "7.2.10 Speed too low" on page 110.

7.4.2 Oil discharge through water outlet

Possible cause	Action
Valve(s) in outlet line closed.	Open the valve(s) and adjust to normal back pressure.
Disc stack clogged.	Clean the bowl discs.
Seal ring under gravity disc is defective.	Fit a new seal ring.
Bowl incorrectly assembled.	Examine and make correct.

8 *Technical Reference*

Contents

8.1 Technical data	116	8.8 Drawings	139
8.1.1 Gravity disc nomogram	120	8.8.1 Cross-section	139
8.2 Basic size drawing	122	8.8.2 Exploded view	140
8.2.1 Dimensions of connections	123	8.8.3 Water adding device (option)	141
8.3 Connection list	124	8.8.4 Pump	142
8.4 Basic size drawing, for heater	125	8.8.5 Foundation drawing	143
8.4.1 Dimensions of connections	126	8.8.6 Lifting instruction	144
8.5 Connection list, for heater	127	8.8.7 Electric motor	146
8.6 Interface description	128	8.8.8 Machine plates and safety labels	148
8.6.1 Definitions	128	8.8.9 Cover interlocking switch (option)	150
8.6.2 Component description and Signal processing Electrical Connections	129	8.9 Storage and installation	151
8.6.3 Function graph and running limitations	130	8.9.1 Storage and transport of goods	151
8.7 Lubricants	131	8.9.2 Planning and installation	153
8.7.1 Lubrication chart, general	131	8.9.3 Foundations	156
8.7.2 Recommended lubricating oils	133		
8.7.3 Recommended oil brands	134		
8.7.4 Recommended lubricants	137		

8.1 Technical data

Alfa Laval ref. 556001 rev. 0

Units according to ISO Standard.

The manufacturer reserves the right to change specifications without notice.

Product number	881145-09-01
Separator type	MAB 103B-24
Purpose	Continuous purification of heavy fuel oil or lubricating oil from solid particles and water. or Continuous clarification of heavy fuel oil or lubricating oil from solid particles. The flash point of the oil to be separated must be minimum 60 °C.
Hydraulic capacity	Maximum 1,4 m ³ /h
Process capacity	Maximum oil flow at the maximum permissible oil density 991 kg/m ³ at 15 °C. The density is preferably measured at 50 °C according to ASTM method D 1298-80 and corrected to 15 °C according to ASTM tables D 1250-80. <i>Fuel oils, diesel engine</i> <ul style="list-style-type: none">Distillate: Maximum oil flow viscosity 1,5-5,5 cSt/40 °C 1,15 m³/hMarine Diesel Oil: Maximum oil flow viscosity 13 cSt/40 °C 0,9 m³/h <i>Lubricating oils, by-pass treatment, optimum</i> <ul style="list-style-type: none">R & O type: Maximum oil flow Crosshead diesel 0,4 - 0,5 m³/hDetergent: Maximum oil flow Crosshead diesel 0,3 - 0,4 m³/h Trunk piston diesel 0,2 - 0,3 m³/hSteam turbine: Maximum oil flow 0,8 m³/h
Max. density of sediment	5000 kg/m ³

Max. density of feed 991 kg/m³, (mechanical safety max. 1100 kg/m³)

Feed temperature Minimum 0 °C
Maximum +100 °C

Ambient temperature Minimum +5°C
Maximum +55 °C

Motor 4-pole 0,75 kW standard motor, 50 or 60 Hz, 3-phase.
Direct on-line start.
If Y/D-start is used maximum 5 seconds in Y position.

Power consumption

idling 0,4 kW
running (at max. capacity) 0,6 kW
max. power consumption 0,6 kW (at starting-up)

Speed The prescribed speed of the bowl spindle which must not be exceeded, is stamped on the name plate of the machine.

Gear ratio	40 : 7	43 : 9
<i>Maximum speed of rotation, rpm</i>	50 Hz	60 Hz
Motor shaft speed	1500	1800
Revolution counter speed	71 - 75	85 - 90
Bowl speed	8570	8600

Starting time 3 minutes

Stopping time Running down with brake applied min. 2 minutes
max. 2,5 minutes
without brake 6 minutes (average)

Maximum running time without flow empty bowl 480 minutes
filled bowl 480 minutes

Inlet pump, built-on	Capacity	50 Hz	60 Hz
	529209-82	1150 litres/h	1380 litres/h
	529209-83 (option)	580 litres/h	700 litres/h
	Suction lift Delivery head	Max. 4 m wg (manometric) Max. 15 m wg (manometric)	
Outlet pump, built-on	Capacity	50 Hz	60 Hz
	529209-82	1270 litres/h	1520 litres/h
	529209-83 (option)	640 litres/h	770 litres/h
	Delivery head	15 - 25 m wg (depending on flow and viscosity)	
Sludge and water space volume	0,56 litres		
Required water quality	Fresh water		
Lubrication	see "8.7.1 Lubrication chart, general" on page 131.		
Lubricating oil volume	0,8 litres		
Weight	Separator without motor	Net weight approx. 75 kg.	
	Motor	Approx. 13 kg.	
	Complete bowl	Approx. 13 kg.	
Shipping data	According to "Basic equipment"		
	Weight	100 kg (Net 85 kg)	
	Volume	0,30 m ³	
Sound power level	7,6 bel(A) ISO 3744, 1,2 m ³ /h		
Sound pressure level	64 dB(A) ISO 3744, 1,2 m ³ /h		
Vibration level	Max. for separator in use	9 mm/s (RMS)	
Materials	Bowl spindle, lock ring	steel	
	Frame, lower and upper parts	cast iron ("Centriblue" finish ¹)	
	Collecting cover	silumin (grey finish ¹)	
	Bowl body and hood, disc stack, gravity disc	stainless steel	
	Other bowl parts	brass	
	Other inlet and outlet parts	stainless steel, brass, cast iron	
		¹)An epoxy enamel	

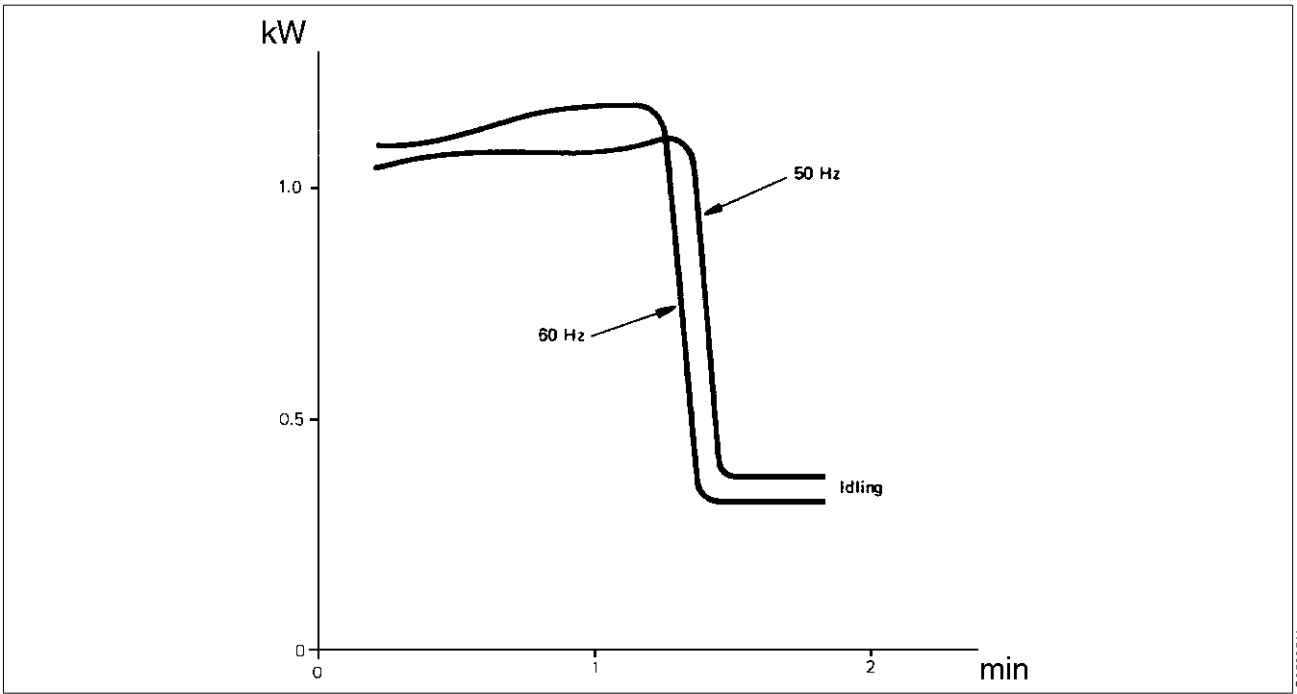

G0599511

Power consumption at startup, power input vs time

8.1.1 Gravity disc nomogram

Alfa Laval ref. 556414 rev. 0

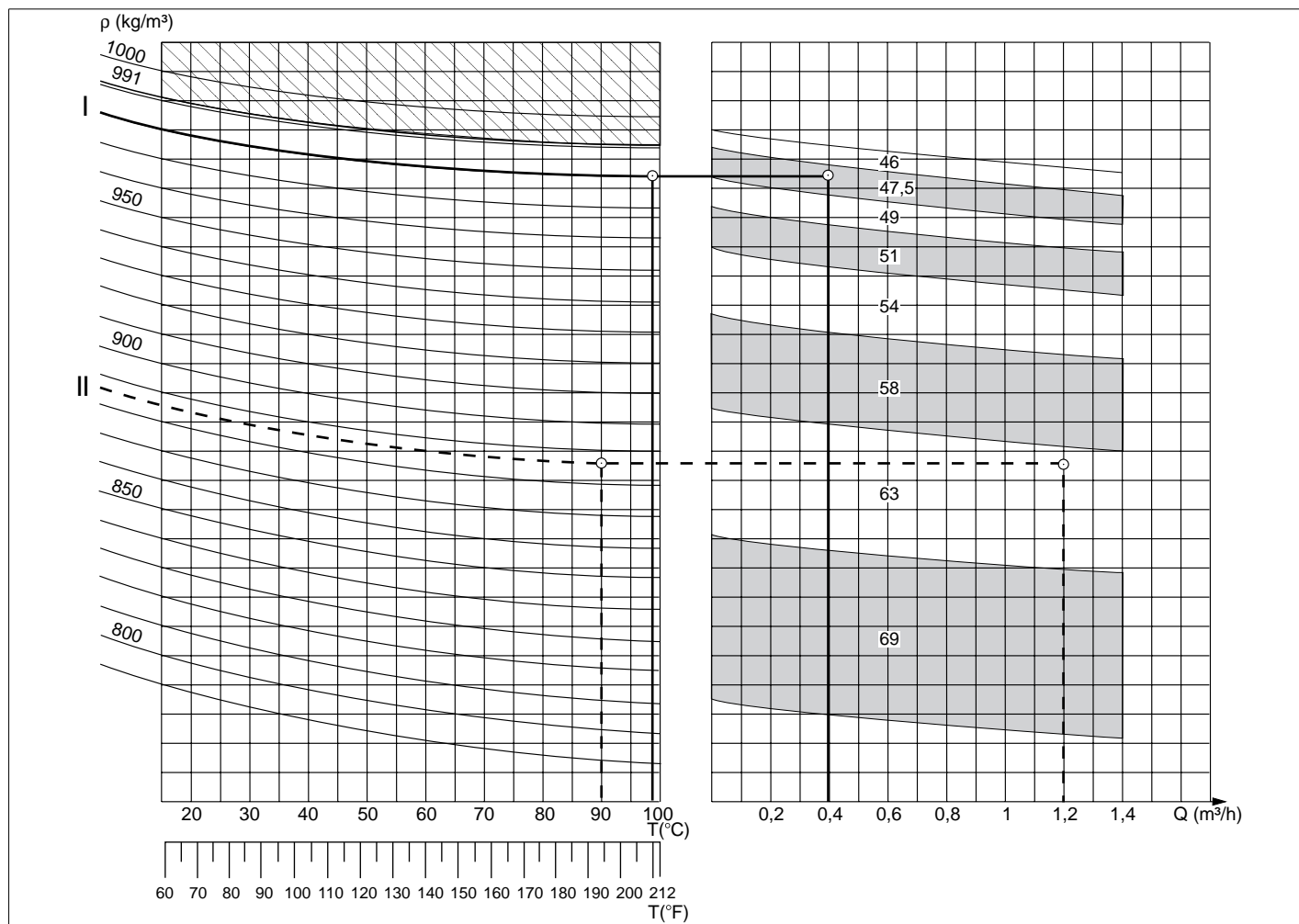

ρ = Density of oil in kg/m^3 at 15 $^{\circ}\text{C}$
 Q = Throughput in m^3/h
 T = Separating temperature in $^{\circ}\text{C}$ or $^{\circ}\text{F}$

Selection of gravity disc

The best separating results are obtained by using a gravity disc with as large a hole as possible, one which will not cause a broken water seal in the bowl or an emulsification in the water outlet.

The presence of salt water may demand the use of gravity disc with bigger hole than indicated in the nomogram (the nomogram is based on the density properties of fresh water).

Example I in nomogram

Density of oil	980kg/m ³ at 15 °C
Separating temp.	98 °C
Troughput	0,4 m ³ /h
Hole diameter	Ø 47,5 mm

Example II in nomogram

Density of oil	886kg/m ³ at 15 °C
Separating temp.	90 °C
Troughput	1,2 m ³ /h
Hole diamete	Ø 63 mm

8.2 Basic size drawing

Alfa Laval ref. 556939 rev. 0

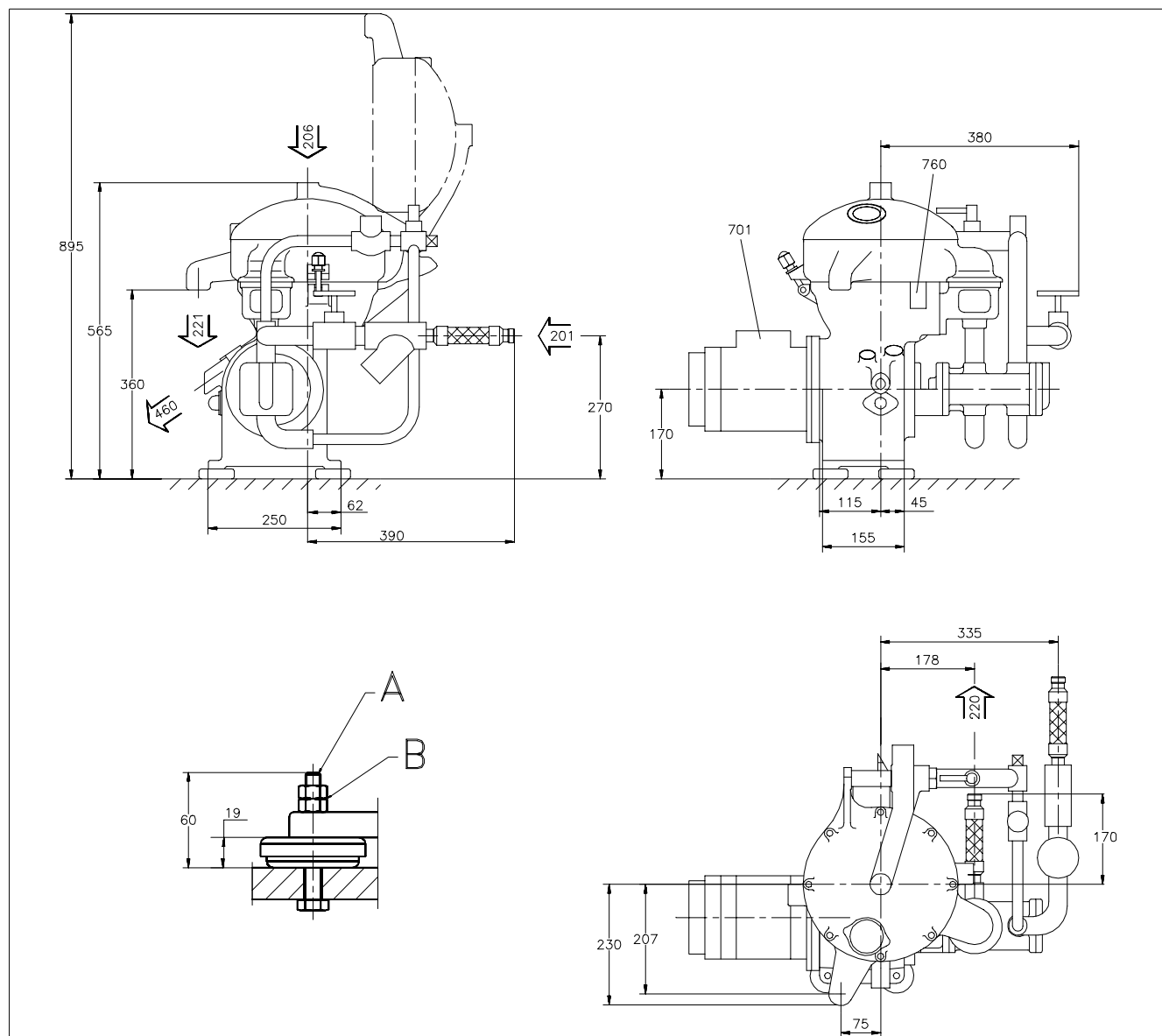

- A. Screw 3/8-16UNC
- B. Tightening torque 16 Nm locked with lock nut

Data for connections see "8.3 Connection list" on page 124.

8.2.1 Dimensions of connections

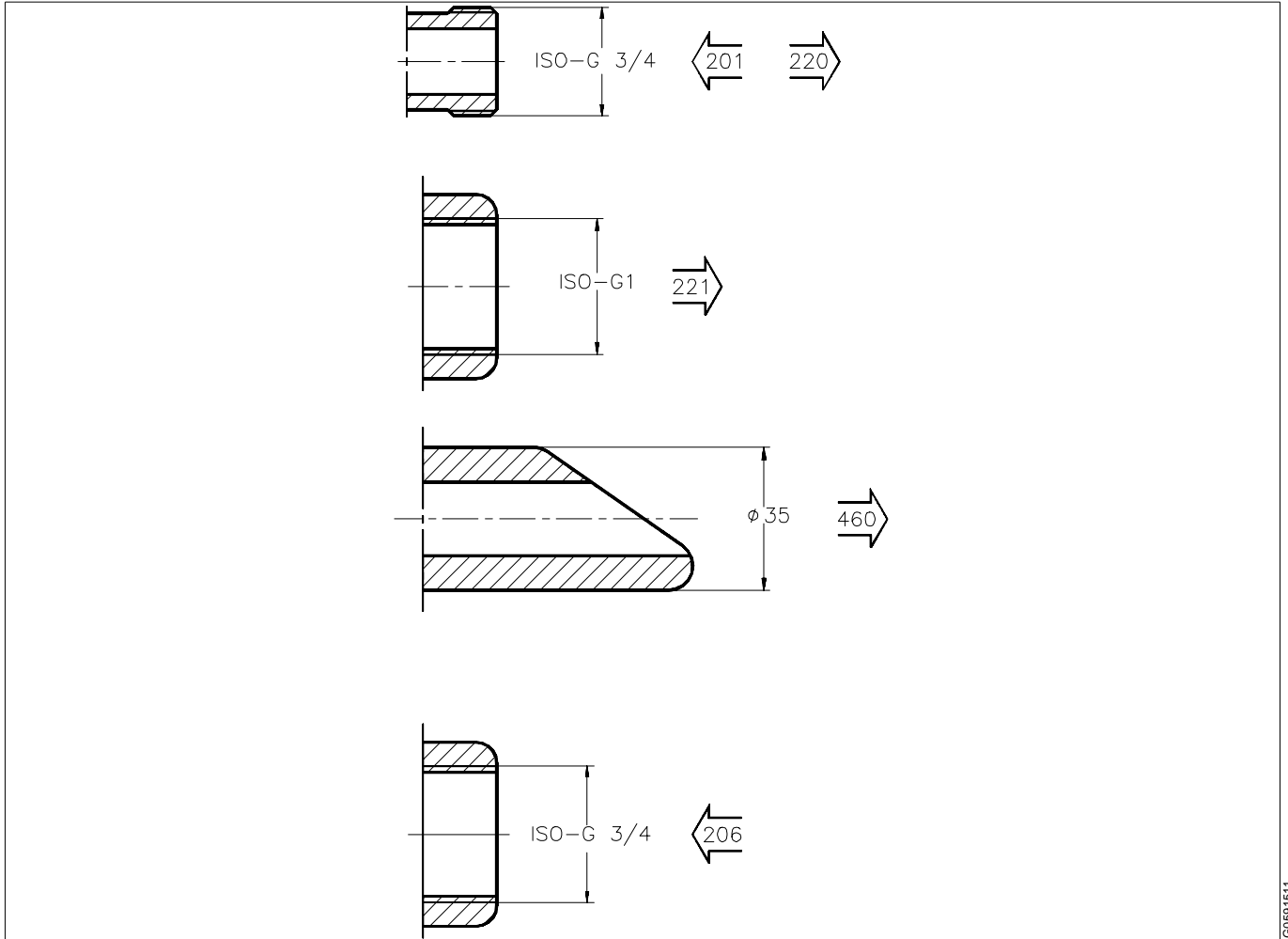

Data for connections, see chapter "8.3 Connection list" on page 124.

All connections to be installed non-loaded and flexible.

8.3 Connection list

Alfa Laval ref. 556989 rev. 0

Connection No.	Description	Requirements/limit
201	Inlet for process liquid, (to pump) - Permitted temperatures	max. 100 °C, min. 0 °C
206	Inlet for water seal	Fresh water, approx 1 litre (depending on gravity disc)
220	Outlet for light phase (oil from pump)	
221	Outlet for heavy phase (water)	no counter pressure
460	Drain of frame	
701	Motor for separator - Max. deviation from nominal frequency	±5%
760	Cover interlocking switch (delivered as option) Type: Double, two-way microswitch Switch rating: Voltage Current	Max. 500 V Max. 3 A

8.4 Basic size drawing, for heater

Alfa Laval ref. 556928 rev. 0

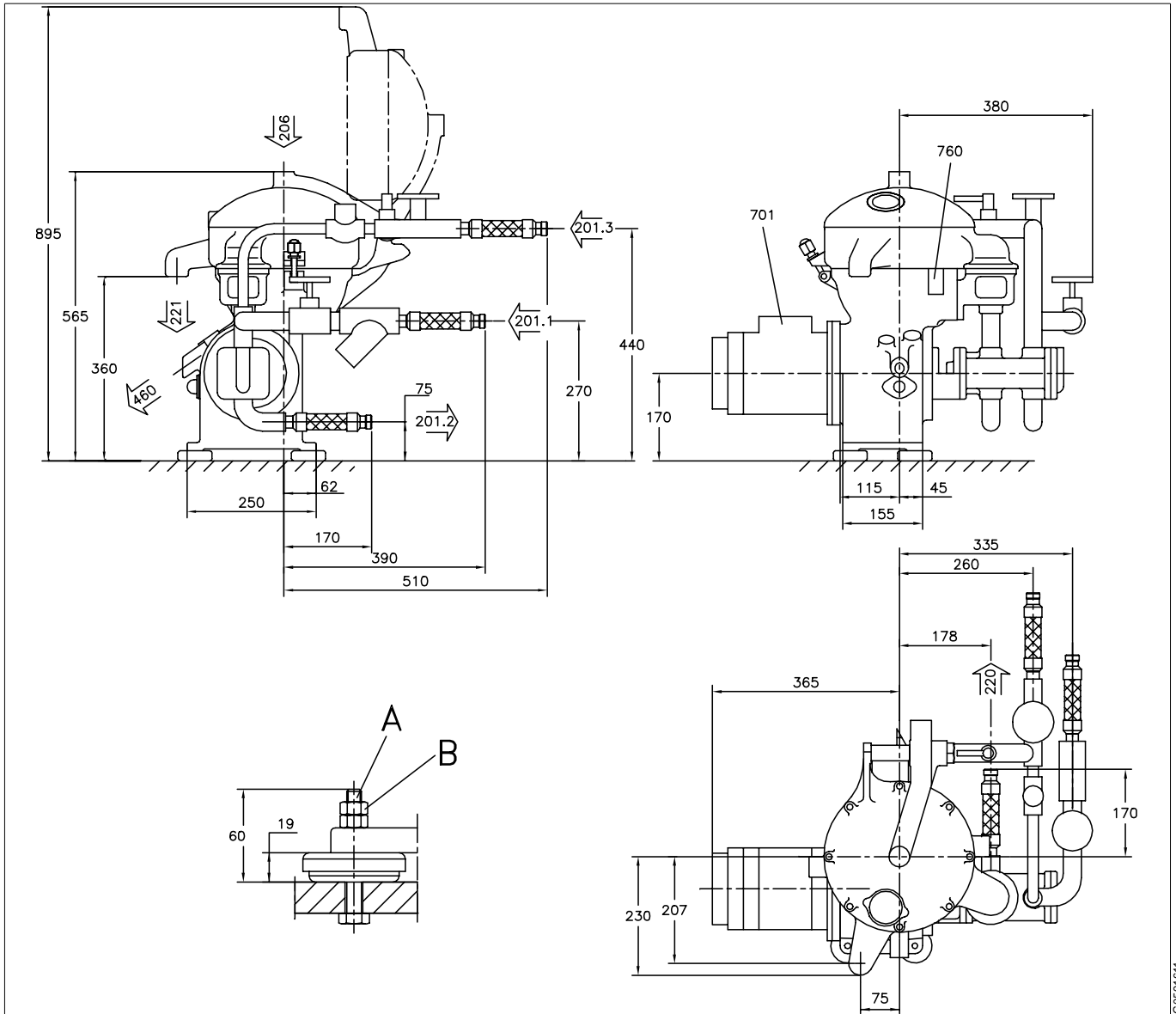

- A. Screw 3/8-16UNC
- B. Tightening torque 16 Nm
locked with lock nut.

Data for connections see "8.5 Connection list, for heater" on page 127.

8.4.1 Dimensions of connections

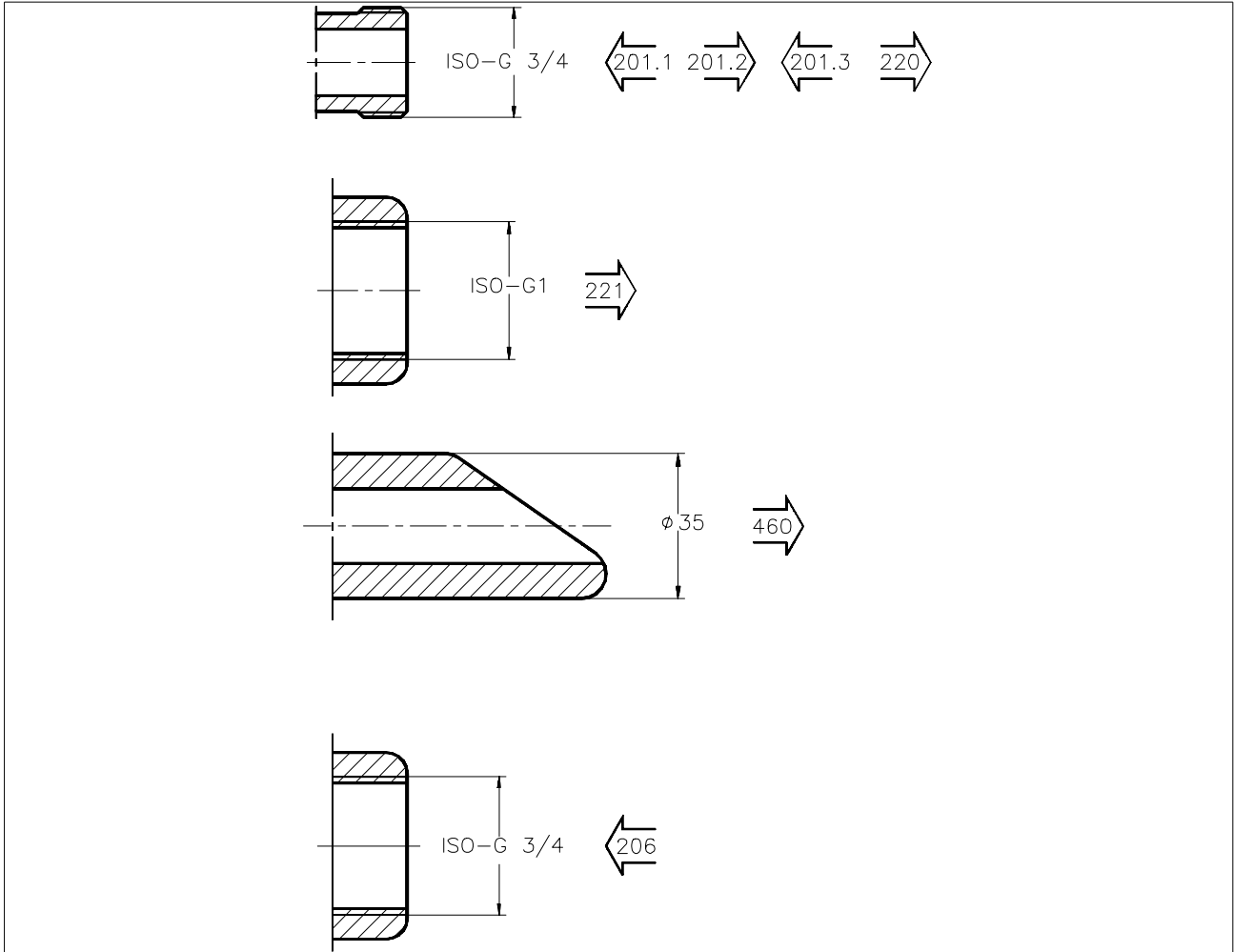

60591711

Data for connections, see chapter "8.3 Connection list" on page 124.

All connections to be installed non-loaded and flexible.

8.5 Connection list, for heater

Alfa Laval ref. 556986 rev. 0

Machine with Pre-Heater.

Connection No.	Description	Requirements/limit
201.1	Inlet for process liquid, (to pump) - Permitted temperatures	max. 100 °C, min. 0 °C
201.2	Outlet for process liquid, (from pump to heater)	
201.1	Inlet for process liquid, (from pump to separator)	
206	Inlet for water seal	Fresh water, approx. 1litre (depending on gravity disc)
220	Outlet for light phase (oil from pump)	
221	Outlet for heavy phase (water)	no counter pressure
460	Drain of frame	
701	Motor for separator - Max. deviation from nominal frequency	±5%
760	Cover interlocking switch (delivered as option) Type: Double, two-way microswitch Switch rating: Voltage Current	Max. 500 V Max. 3 A

8.6 Interface description

Alfa Laval ref. 557119 rev. 0

In addition to the Connection List this document describes limitations and conditions for safe control, monitoring and reliable operation.

At the end of the document a function graph and running limitations are to be found.

8.6.1 Definitions

Standstill means:

- The machine is assembled correctly.
- All connections are installed according to Connection List, Interconnection Diagram and Interface Description.

Start means:

- The power to the separator is on.
- The acceleration is supervised to ensure that a certain speed has been reached within a certain time. See “8.1 Technical data” on page 116.

The start procedure continues until the full speed has been reached and a stabilization period has passed (about 1 minute).

Normal stop means:

- Stopping of the machine at any time with feed or safety/backup liquid and with brake applied.

Safety stop means:

The machine must be stopped in the quickest and safest way due to vibrations or process reasons.

Comply to following conditions:

- The bowl must be kept filled.
- The machine must not be restarted before the reason for the Safety stop has been investigated and action has been taken.

In case of emergency condition in the plant, the machine must be stopped in a way that is described in EN 418.

8.6.2 Component description and Signal processing Electrical Connections

Separator motor 701

The separator is equipped with a 3-phase DOL-started (direct on line) motor. The separator can also be started by a Y/D starter, but then the time in Y-position must be maximized to 5 seconds.

Cover interlocking switch 760 (Option)

The cover of the separator is equipped with an interlocking switch. When the cover is closed the interlocking circuit in the starter control is closed and the separator could be started.

Signal processing:

The circuit is closed when the collecting cover of the separator is closed.

The interlocking switch should be connected so that starting of the motor is prevented when the separator collecting cover is not closed.

8.6.3 Function graph and running limitations

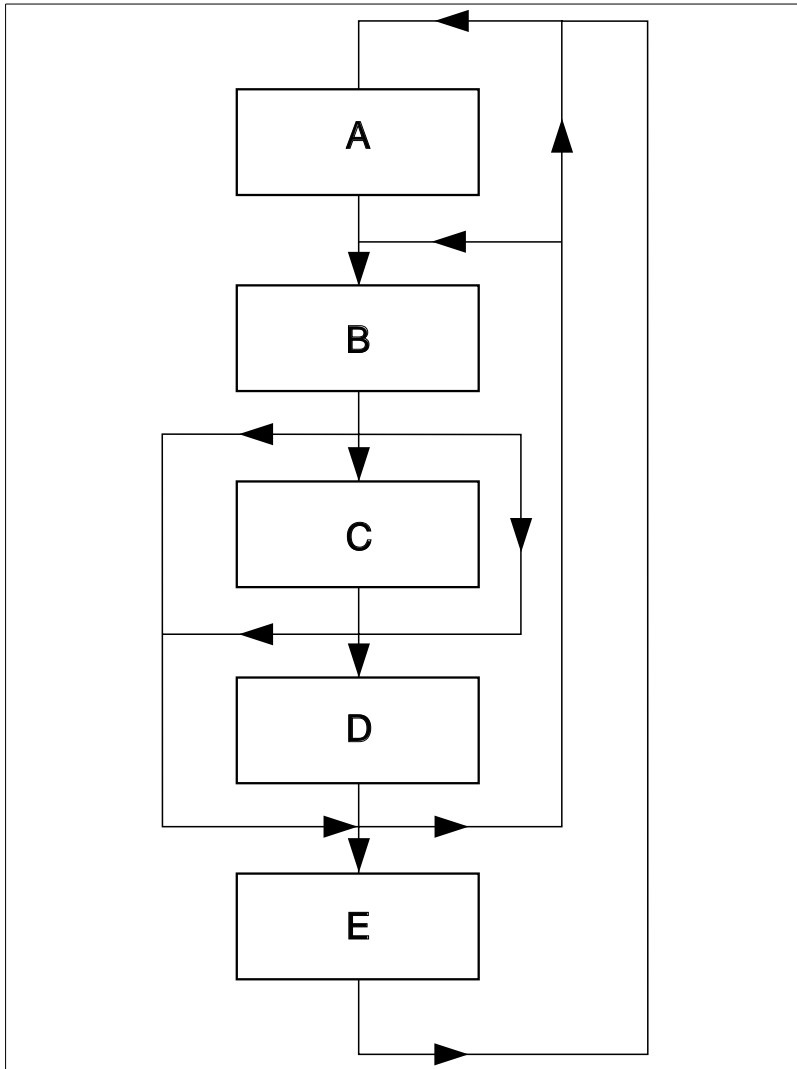

- A. Stand still
- B. Starting mode
- C. Running mode
- D. Stop mode
- E. Safety stop mode

8.7 Lubricants

8.7.1 Lubrication chart, general

Alfa Laval ref. 553216-01 rev. 5

Lubricating points	Lubricants
Bowl spindle ball bearings and buffers are lubricated by oil mist	Lubricating oil as specified in "8.7.2 Recommended lubricating oils" on page 133
Bowl spindle taper	Lubricating oil (only a few drops for rust protection)
Buffers of bowl spindle	Lubricating oil
Bowl: Sliding contact surfaces and pressure loaded surfaces such as lock rings, threads of lock rings, bowl hood, and cap nut	Pastes as specified in "8.7.4 Recommended lubricants" on page 137 If not specified otherwise, follow the supplier's recommendation about method of application
Rubber seal rings	Grease as specified in "8.7.4 Recommended lubricants" on page 137
Friction coupling ball bearings	The bearings are packed with grease and sealed and need no extra lubrication
Electric motor (if nipples are fitted)	Follow manufacturer's instructions

Alfa Laval Lubricating Oil Groups:

- **Group A oil:** a high quality gear oil on paraffin base with stable AW (anti wear) additives.
- **Group B oil:** a high quality gear oil on paraffin base with stable EP (extreme pressure) additives.
- **Group D oil:** a synthetic base oil with additives stable at high operating temperatures.

Do not mix different oil brands or oils from different oil groups.

Always use clean vessels when handling lubricating oil.

Great attention must be paid not to contaminate the lubricating oil. Of particular importance is to avoid mixing of different types of oil. Even a few drops of motor oil mixed into a synthetic oil may result in severe foaming.

Any presence of black deposits in a mineral type oil is an indication that the oil base has deteriorated seriously or that some of the oil additives have precipitated. Always investigate why black deposits occur.

If it is necessary to change from one group of oil brand to another it is recommended to do this in connection with an overhaul of the separator. Clean the gear housing and the spindle parts thoroughly and remove all deposits before filling the new oil.

NOTE

Always clean and dry parts (also tools) before lubricants are applied.

NOTE

Check the oil level before start. Top up when necessary. Oil volume see "4.1.3 Before normal start" on page 31.

It is of utmost importance to use the lubricants recommended in our documentation. This does not exclude, however, the use of other brands, provided they have equivalently high quality properties as the brands recommended. The use of oil brands and other lubricants than recommended, is done on the exclusive responsibility of the user or oil supplier.

Applying, handling and storing of lubricants

Always be sure to follow lubricants manufacturer's instructions.

8.7.2 Recommended lubricating oils

Alfa Laval ref. 553219-10 rev. 0

Three different groups of lubricating oils are approved for type of frame B 1200, B 1300, B 1400 with motor <3,7 kW.

They are designated as Alfa Laval lubricating oil groups A,B and D.

The numerical value after the letter states the viscosity grade.

The corresponding commercial oil brands according to “ Alfa Laval lubricating oil group A/220” on page 134.

Ambient temperature °C	Alfa Laval lubricating oil group	Time in operation Oil change interval
between +5 and +45	A/220 B/220	1500 h
between ±2 and +65	D/220	2000 h

Note:

- In a new installation or after change of gear transmission, change oil after 200 operating hours.
- When the separator is operated for short periods, lubricating oil must be changed every 12 months even if the total number of operating hours is less than stated in the recommendations above.
- Check and prelubricate spindle bearings on separators which have been out of service for 6 months or longer.
- In seasonal operation: change oil before every operating period.

8.7.3 Recommended oil brands

Alfa Laval lubricating oil group A/220

Alfa Laval ref. 553218-01 rev. 0

Viscosity grade VG (ISO 3448/3104) 220

Viscosity index VI (ISO 2909) > 92

Manufacturer	Designation
Castrol	Alpha ZN 220
Esso Standard Oil/ Svenska Statoil/Exxon	Teresso 220 Terrestic 220
Lubmarine/Beijer (ELF Brand designation according to ELF)	Polytelis 220
Mobil	DTE Oil BB
Nynäs	TD EX 220
Optimol Ölwerke	Ultra 220
Q8/Kuwait (Gulf)	Harmony AW 220
Shell	Tellus C 220 Tellus 220
Texaco/Caltex	Regal R&O 220 Paper Machine HD 220

Alfa Laval lubricating oil group B

Alfa Laval ref. 553218-02 rev. 1

Viscosity grade VG (ISO 3448/3104) 220

Viscosity index VI (ISO 2909) > 92

Manufacturer	Designation
Bel-Ray	100/06-220
BP	Energol GR-XP 220
Castrol	Alpha SP 220
Chevron	Ultragear 220 (NL Gear Compound 220)
DIN 51517, part 3	CLP 220
Esso Standard Oil/ Svenska Statoil/Exxon	Spartan EP 220
Fina/Petrofina	Giran 220
ISO/DIS 6743/6	L-CKC-220
Lubmarine/Beijer (ELF Brand designation according to ELF)	Epona Z 220
Mobil	Mobilgear 630 (Mobilgear SHC 220)
Nynäs	(GL 220)
Optimol Ölwerke	Optigear BM 220 (5150)
Q8/Kuwait (Gulf)	Goya 220
Shell	(Lorina 220) Omala 220 Delima HT 220
Texaco	Meropa 220
Soviet (GHOST-) Standard	IGP-152 according to TU 38.101413-90

Alfa Laval lubricating oil group D / 220

Alfa Laval ref. 553218-03 rev. 0

Viscosity grade VG (ISO 3448/3104) ¹⁾ 220

Viscosity index VI (ISO 2909) ²⁾ > 135

Manufacturer	Designation
Alfa Laval Separation AB	542690-80 20 litres
	542690-81 4 litres
	542690-82 208 litres
	542690-83 1 litre
BP	Energol HTX 220
Castrol	Alpha Syn T 320
Lubmarine/Beijer (ELF Brand designation according to ELF)	Epona SA 320
Mobil	SHC 632
Shell	(Delima HT 320)* (Paolina 320)

1) According to ISO 3448/3104

2) According to ISO 2909

8.7.4 Recommended lubricants

Pastes and bonded coatings for non-food applications

Alfa Laval ref. 553217-01 rev. 3

Manufacturer	Designation	Alfa Laval No.	Application
Gleitmolybdän	Gleitmo 705 K or 805 K varnish 901 Gleitmo Paste G rapid	537086-04	All pressure loaded surfaces
Dow Corning	Molykote paste 1000 spray D321 R varnish D321 R	537086-02 535586-01 535586-02	
Rocol	Antiscuffing paste (ASP)		
Klueber	Wolfracoat C paste		
Russian Standard	VNII NP 232 Gost 14068-90		

Silicone grease

Alfa Laval ref. 553217-01

Manufacturer	Designation	Alfa Laval No.
Dow Corning	Molykote 111 compound 100 gr 25 gr	539474-02 539474-03
Gleitmolybdän	Silicone paste 750	
Wacker	Silicone Paste P (vacuum paste)	

Greases for ball and roller bearings

Alfa Laval ref. 553217-01 rev. 0

Manufacturer	Designation	Alfa Laval No.
BP	Energrease MMEP2 Energrease LS2	
Castrol	Spheerol SW2 EP Spheerol EPL2	
Chevron	Duralith grease EP2	
Exxon	Beacon EP2	
Mobil	Mobilith SHC 460 Mobilux EP2	
Gulf	Gulflex MP2	
Q8	Rembrandt EP2	
Shell	Cailithia EP Grease T2 Alvania EP Grease 2 or R.A	
SKF	LGEP2 or LGMT2	
Texaco	Multifak AF B2 Multifak premium 2.3	
Russian Standard	Fiol 2M, Litol 24 TU 38.201.188	

8.8 Drawings

8.8.1 Cross-section

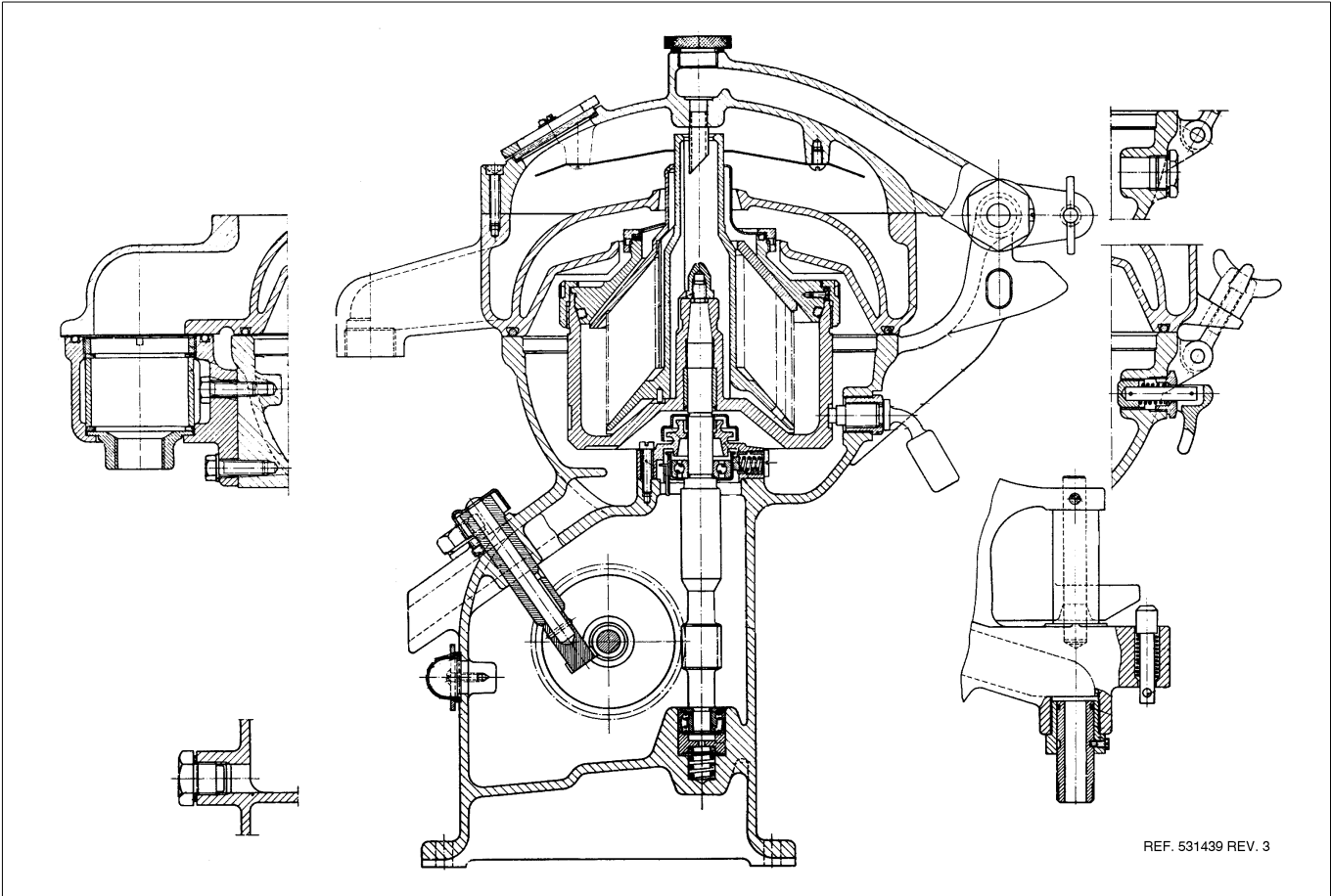

Cross-section of separator

8.8.2 Exploded view

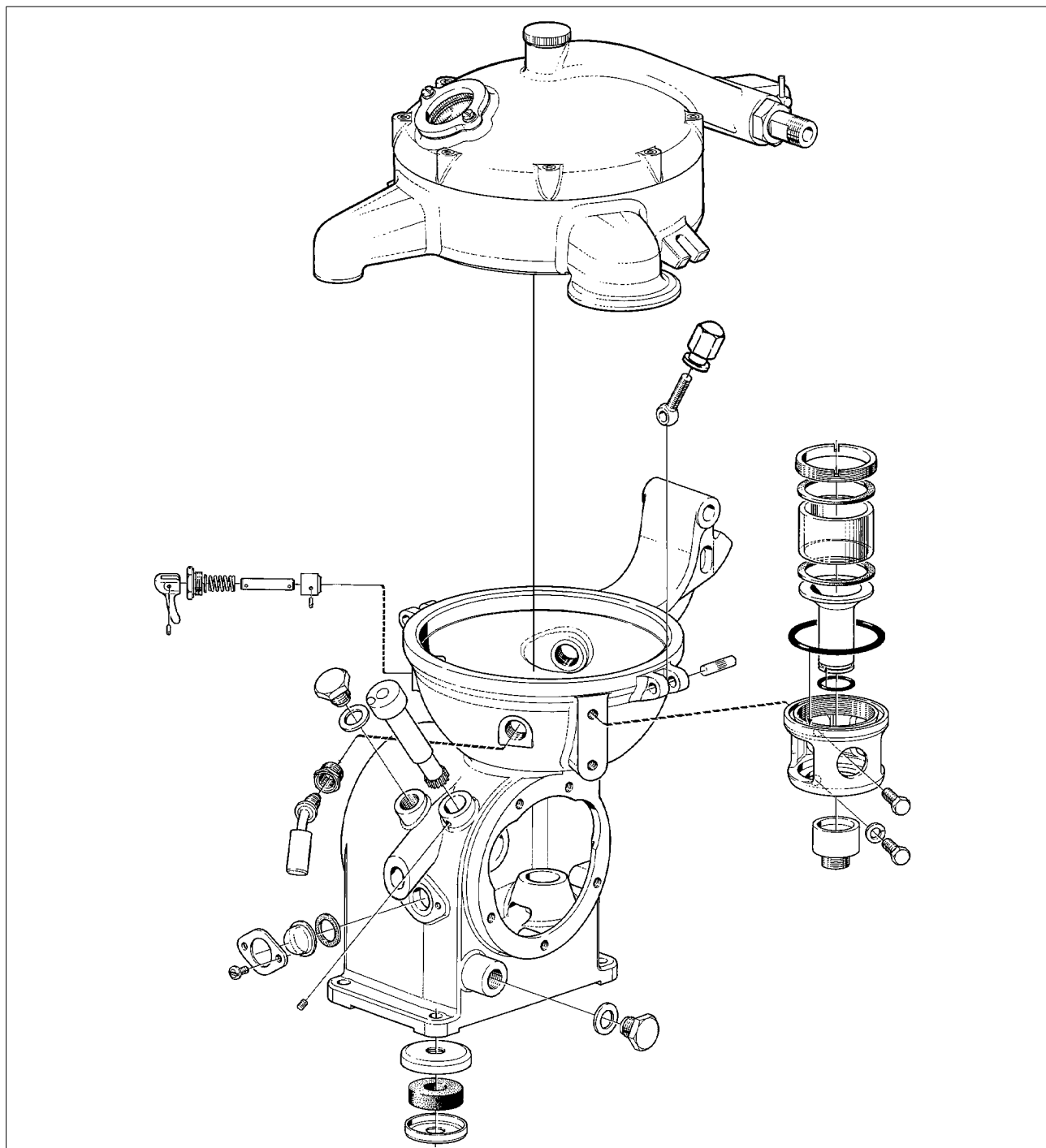

Exploded view of separator frame

C01220B1

**8.8.3 Water adding device
(option)**

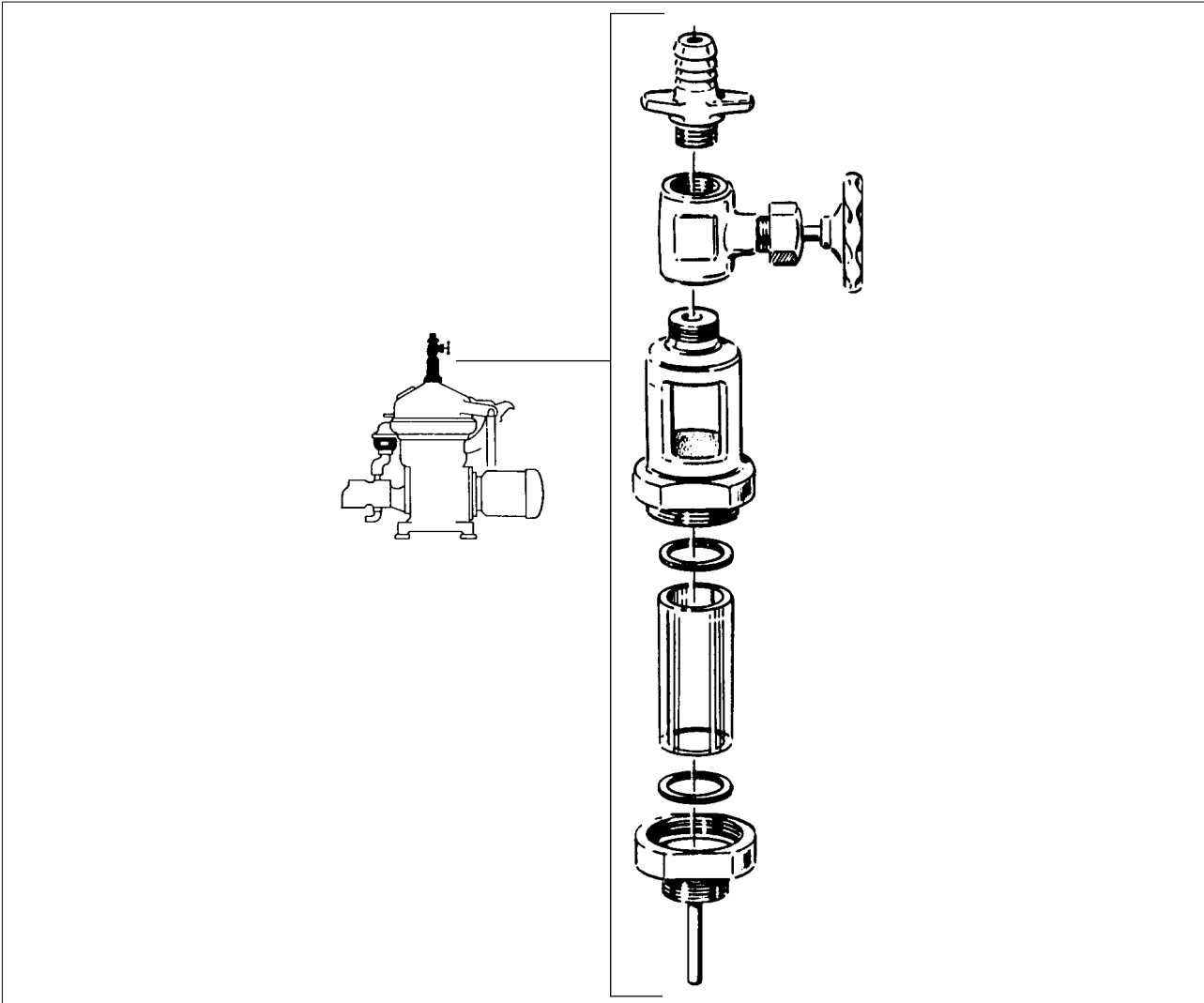

G0877521

8.8.4 Pump

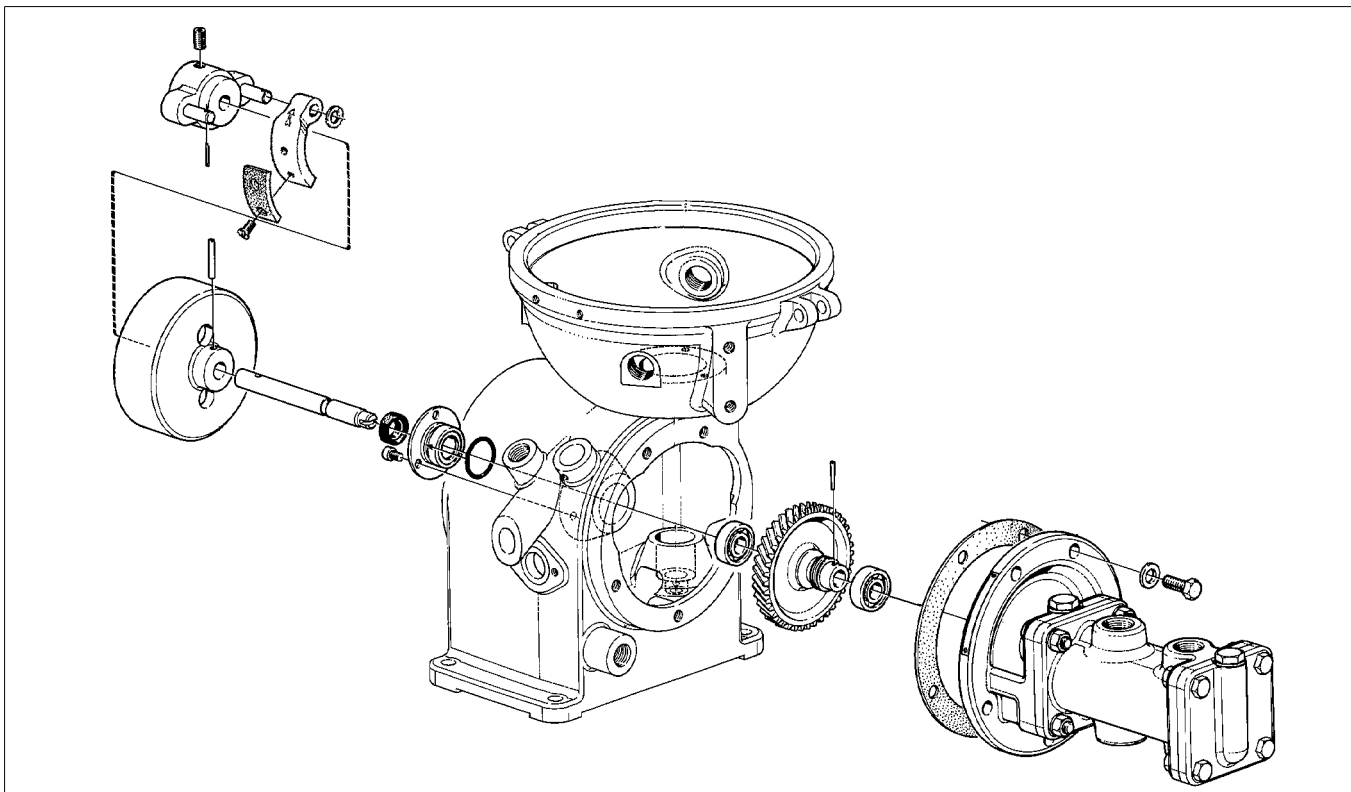

C01221B1

Inlet and outlet pump, exploded view

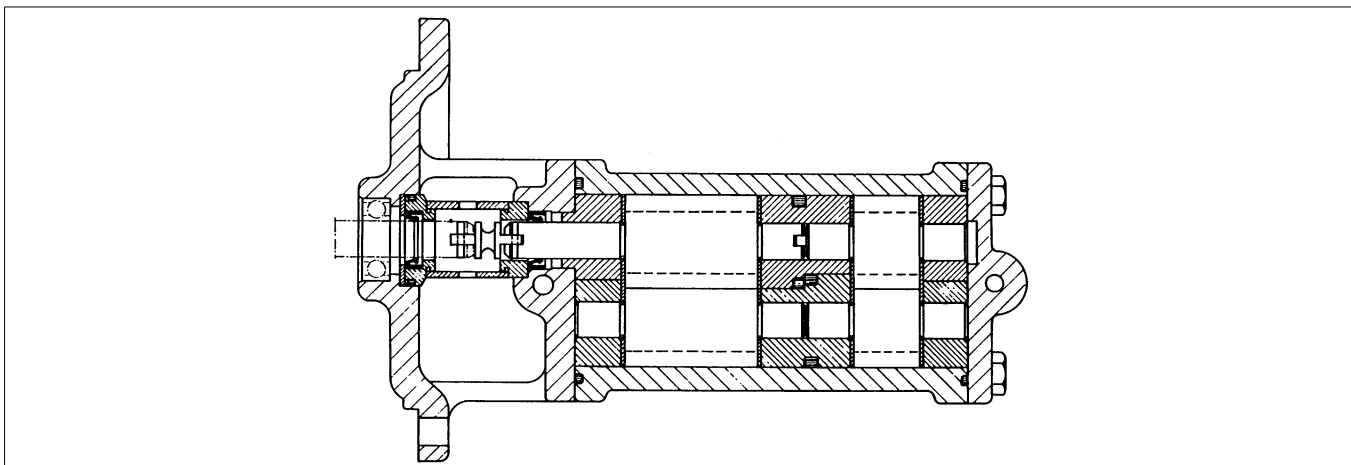

G0604711

Inlet and outlet pump, cross-section

Alfa Laval ref. 529209

8.8.5 Foundation drawing

Alfa Laval ref. 556885 rev. 0

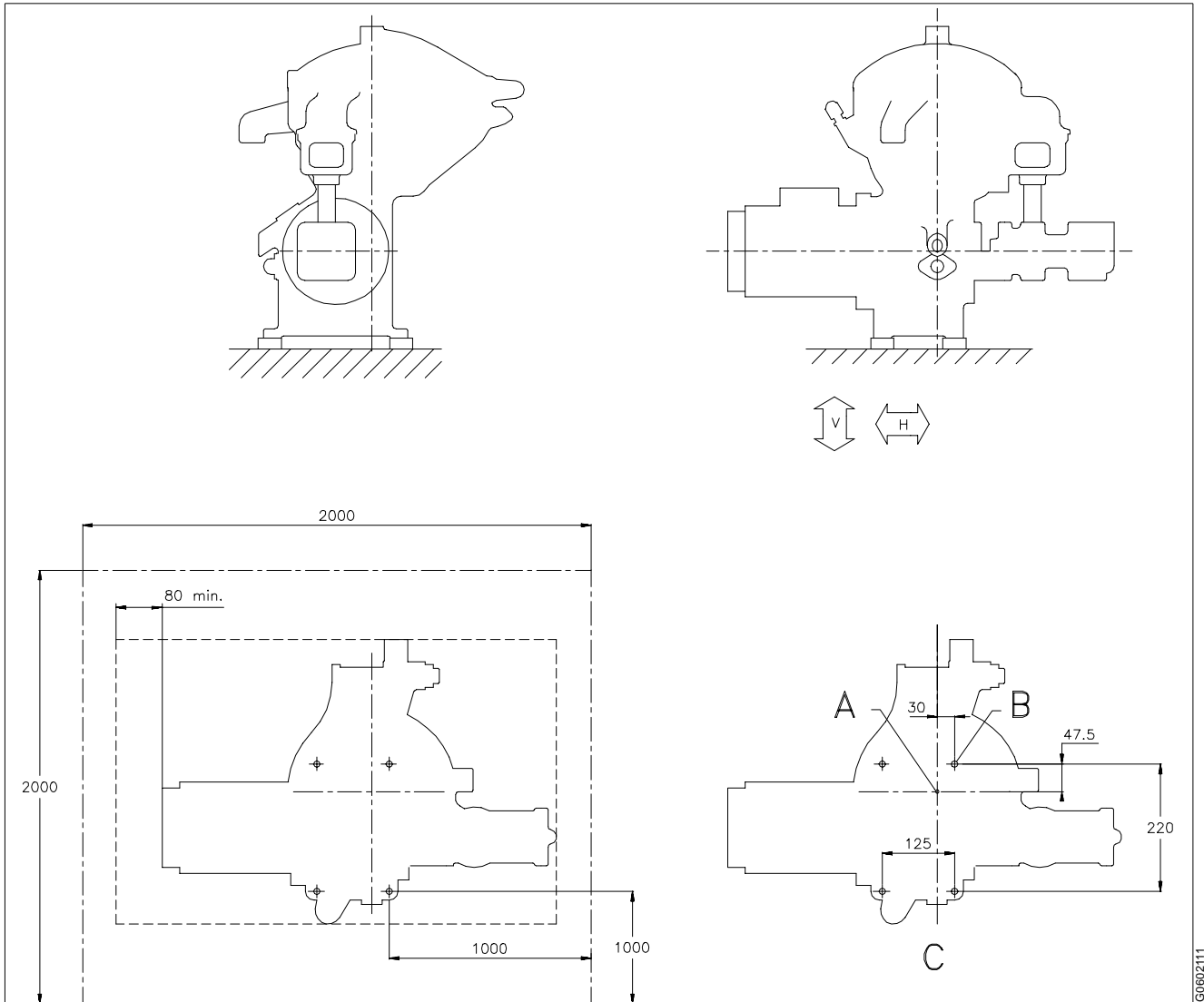

- A Center of separator bowl
- B 4 holes Ø 11,5 for anchorage
- C Service side

— · — · — · Recommended free floor space for unloading when doing service

— · — · — · Min. access area for overhead hoist (no fixed installation within this area)



Vertical force not exceeding 6 kN/foot



Horizontal force not exceeding 6 kN/foot

GC0602111

8.8.6 Lifting instruction

Alfa Laval ref. 556213 rev. 0

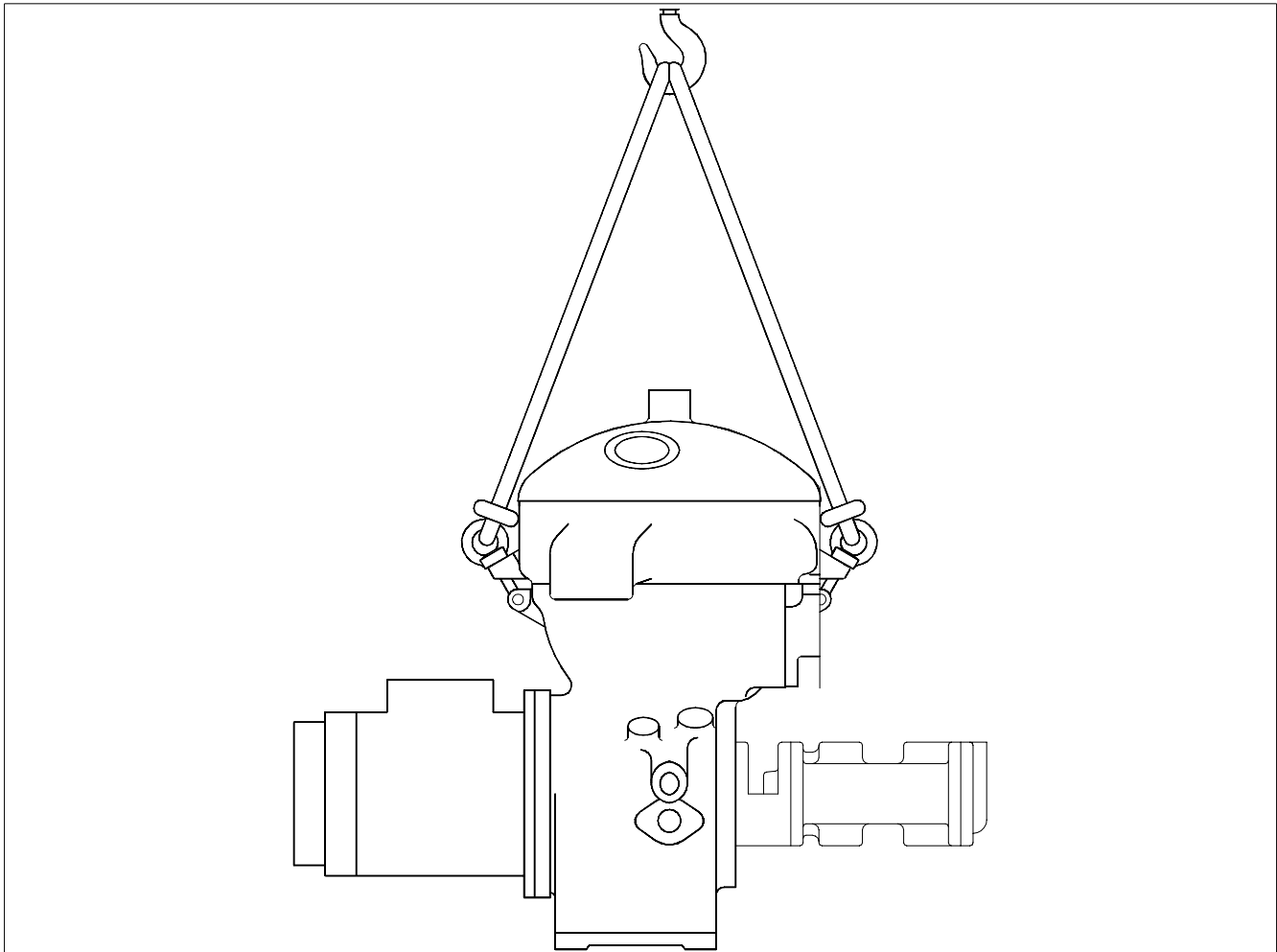

G0591311

Weight to lift 80 kg

NOTE

Never lift the separator with the separator bowl inside.

Lifting the separator

1. Remove cap nut on hinged bolt
2. Remove separator bowl
3. Assemble lifting eye nuts on hinged bolt.

NOTE

Never lift the separator in any other way.

8.8.7 Electric motor

Alfa Laval ref. 551587 rev. 1

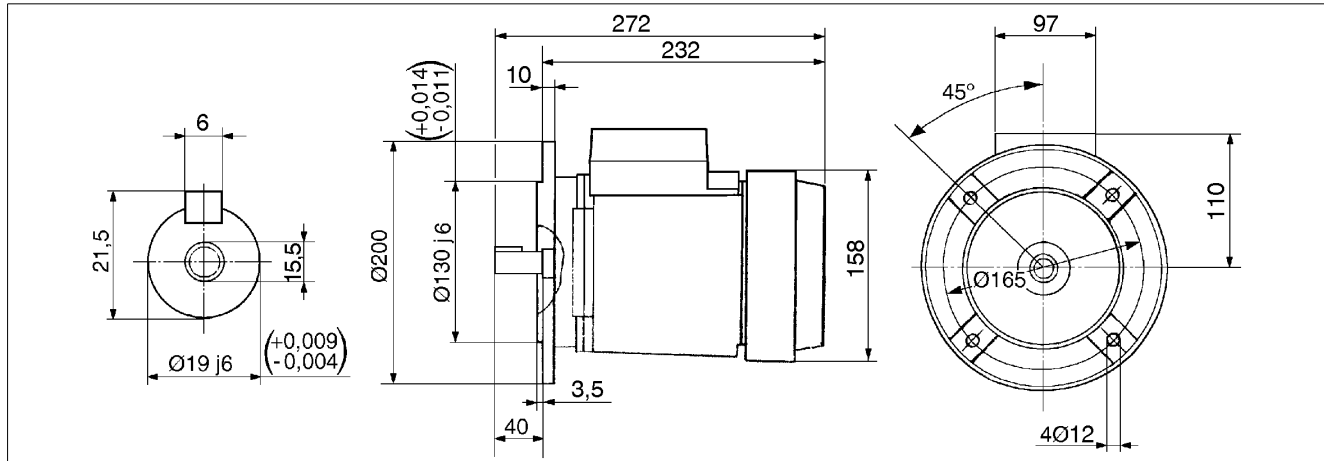

Manufacturer	ASEA
Manufacturers drawing	MK 11D, del B3
Standards	IEC 34-1, IEC 72-2
Size	80B
Type	MT 80 B
Weight	10 kg
Poles	4
Insulation class	F
Bearings	DE 62 04 C3 NDE62 03 C3
Method of cooling	IC41 (IEC 34-6)
Specification	Totally enclosed fan cooled induction motor ¹⁾

Type of mounting		Degree of protection
	IM 1001	IP 44
	IM 3001	
	IM 3011	
	IM 3031	

¹⁾ The motors can be designed to fulfill requirements of following Classification Societies:

Lloyds Register of shipping	(LRS) (Essential Service)
Det Norske Veritas	(DnV) (Essential Service)
Germanischer Lloyd	(GL) (Essential Service)
Bureau Veritas	(BV) (Essential Service)
American Bureau of shipping	(ABS) (Essential Service)
Registro Italiano Navale (RINA)	(Essential Service)
USSR Register of Shipping	(RSU) (Essential Service)
Japanese Classification Society	(NKK) (Essential Service)

Required classification society must always be specified when ordering. Factory test certificate to be enclosed at the delivery.

Rated output (kW) valid for temp-rise max. 90 °C

Article No	Output kW	Speed RPM	Freq Hz	Voltage V	Current A	Pow.fac cos φ	$I_{st} / I^{1)}$	Therm ²⁾ °C	Note
551587-01	0,75	1410	50	220 D	3,6	0,75	4,5		
551587-02	0,75	1690	60	220 D	3,1	0,84	4,6		
551587-03	0,75	1410	50	380 Y	2,1	0,75	4,5		
551587-04	0,75	1410	50	415Y	2,1	0,70	4,8		
551587-05	0,9	1700	60	440 Y	2,1	0,81	4,5		

1) I_{st} / I =starting current / rated current at direct on-line starting.

2) Thermistors tripping temperature if applicable.

8.8.8 Machine plates and safety labels

Alfa Laval ref. 549438 rev. 2

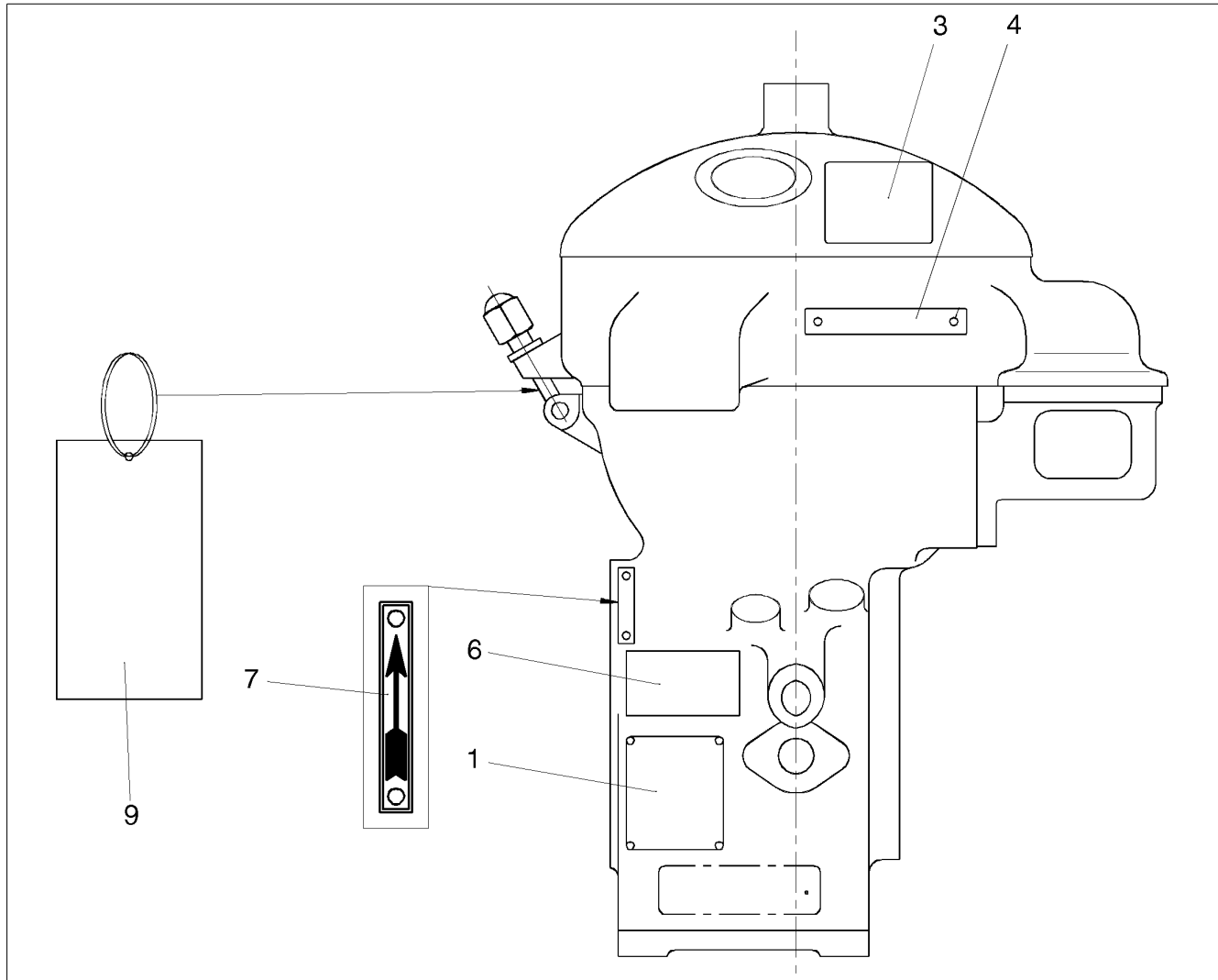

1. Machine plate

Separator	MAB 103B-24
Manufacturing serial No / Year	XXXX
Product No	881145-09-01
Frame	549377-02/04 (50/60 Hz)
Bowl	524700-88
Max. speed (bowl)	8571 r/min. (50 Hz), 8600 r/min. (60 Hz)
Direction of rotation (bowl)	←
Speed motor shaft	1500 r/min. (50 Hz), 1800 r/min. (60 Hz)
El. current frequency	50/60 Hz
Recommended motor power	0,75 kW
Max. density of feed	1100 kg/m ³
Max. density of sediment	5000 kg/m ³
Process temperature min./max.	0/100 °C



G0602821

S0061411

3. Safety label

Text on label:

DANGER

Read the instruction manuals **before** installation, operation and maintenance. Consider inspection intervals.

Failure to strictly follow instructions can lead to fatal injury.

If excessive vibration occur, **stop** separator and **keep bowl filled** with liquid during rundown.

Out of balance vibration will become worse if bowl is not full during rundown.

Separator must **stop rotating** before **any** dismantling work is started.

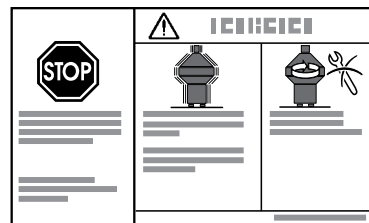

S0061521

4. Name plate



S0063211

6. Power supply frequency

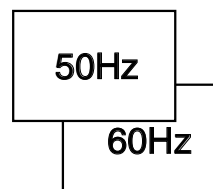

S0063111

7. Arrow

Indicating direction of rotation of horizontal driving device.

9. Stop, follow lifting instruction

This transport label is not permanently fixed to the separator.

8.8.9 Cover interlocking switch (option)

Switch rating, voltage: Max. 500 V

current: Max. 3 A

For other technical information see chapter “8.3 Connection list” on page 124 and “8.6 Interface description” on page 128.

- Contact closed
- Contact open
- BK* Black
- BN* Brown
- BU* Blue
- GN-YW* Green-Yellow

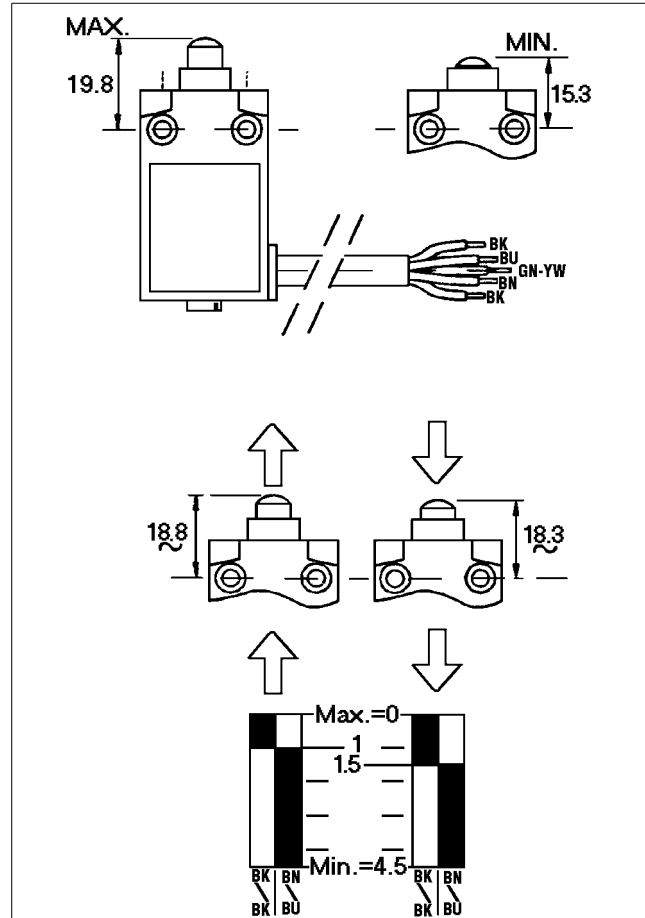

G0648111

8.9 Storage and installation

8.9.1 Storage and transport of goods

Storage

Specification

Upon arrival to the store, **check all components and keep them:**

1. Well stored and protected from mechanical damage and theft.
2. Dry and protected from rain and humidity.
3. Organized in the store in such a way that the goods will be easily accessible when installation is about to take place.

A separator can be delivered with different types of protection:

- Fixed on a pallet.

The separator must be stored in a storage room well protected from mechanical damage and theft and also dry and protected from rain and humidity.

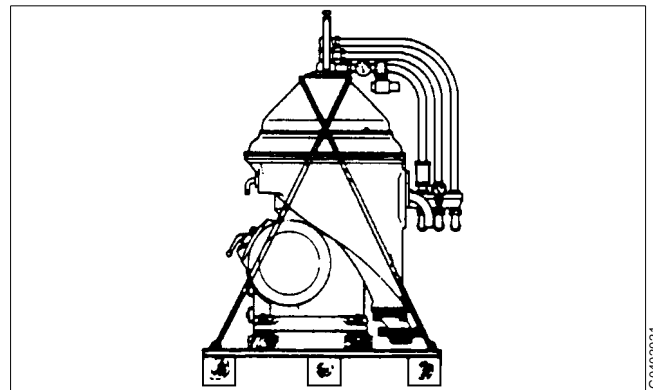

Fixed on a pallet

G0402021

- In a wooden box which is not water tight.

The separator must be stored dry and protected from rain and humidity.

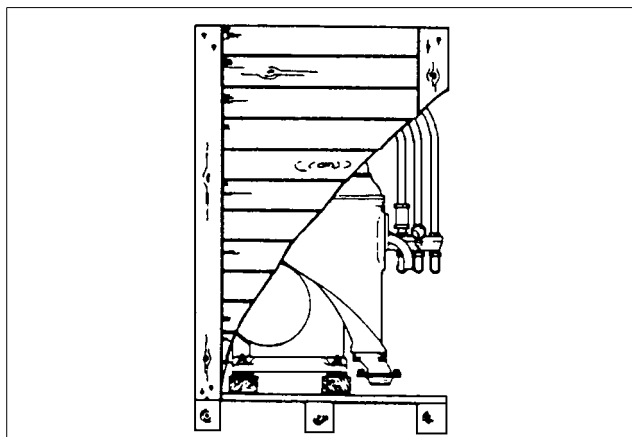

In a wooden box which is not water tight

- In a special water-resistant box for outdoor storage.

The separator and its parts have been treated with an anti-corrosion agent. Once the box has been opened, store dry and protected from rain and humidity.

The packaging for outdoor storage is only to special order.

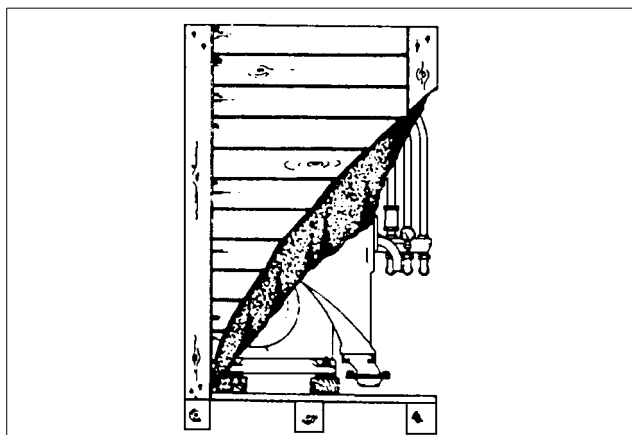

In a special water-resistant box for outdoor storage

Transport

Specification

- During transport of the separator, the frame hood and bowl **must always be removed from the machine.**
- When lifting a separator it must always be **hung securely.** See chapter “5.7 Lifting instructions” on page 76.

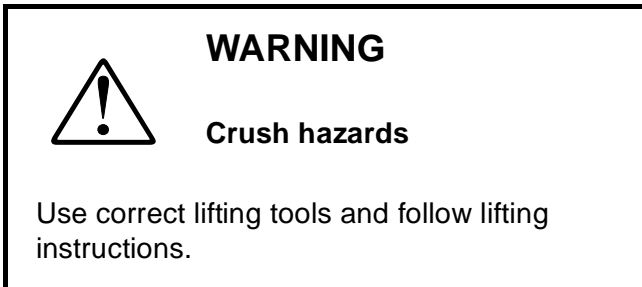

- During erection, all inlets and outlets to separators and accessories must be covered to be protected from dirt and dust.

8.9.2 Planning and installation

Introduction

The requirements for one or more separators can be established by consulting the following documents.

- Basic size drawing
- Connection list
- Interface description
- Interconnection drawing
- Foundation drawing
- Lifting drawing

These are included in this chapter “8 Technical Reference” on page 115.

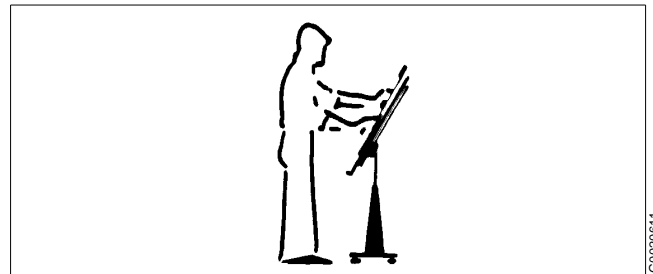

Check the drawings when planning the installation

Important measurements

Important measurements are the minimum lifting height for lifting tackle, shortest distance between driving motor and wall, free passage for dismantling and assembly, maintenance and operation.

Plan your installation with sufficient room for the controls and operation so that instruments are easily visible. Valves and controls must be within convenient reach. Pay attention to space requirements for maintenance work, work benches, dismantled machine parts or for a service trolley.

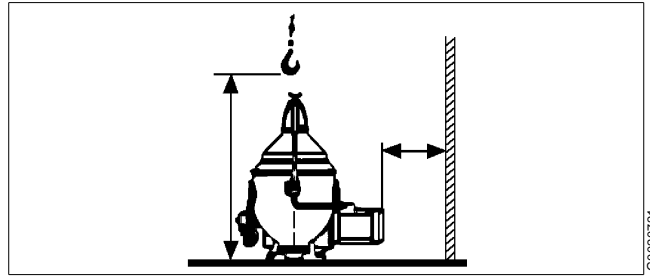

Suitable space must be obtained for the maintenance work

Space for separator

The separator shall be placed in such a way that suitable space for maintenance and repair is obtained.

Specification

- See “8.8.5 Foundation drawing” on page 143 for the service space required with the separator installed.

Recommendation

- The spanner for the large lock ring should have sufficient space to make a complete turn without hitting any of the ancillary equipment surrounding the separator.

Lifting height for transport of bowl

Specification

- A minimum height is required to lift the bowl, bowl parts and the bowl spindle, see “8.8.6 Lifting instruction” on page 144.

Recommendation

- When two or more separators are installed, the lifting height may have to be increased to enable parts from one separator to be lifted and moved over an adjoining assembled separator.

NOTE

Remove the separator bowl before lifting.

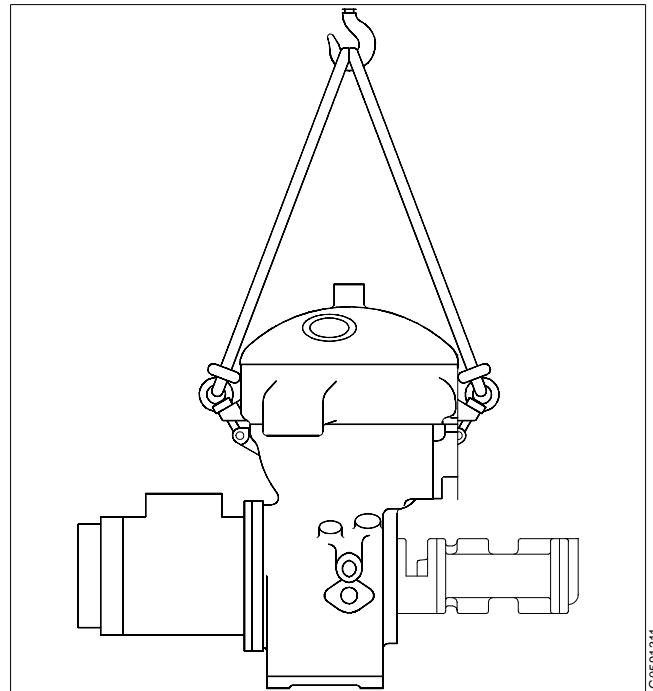

G0591311

Do not lift the separator in any other way



WARNING

Crush hazard

Use correct lifting tools and follow lifting instructions.

Do **not** work under a hanging load.

Space for oil changing

Specification

- The plug for gearbox oil draining must not be blocked by floor plate arrangement, etc.

Recommendation

- It should be possible to place a portable collecting tray under the gearbox drain plug for changing oil.

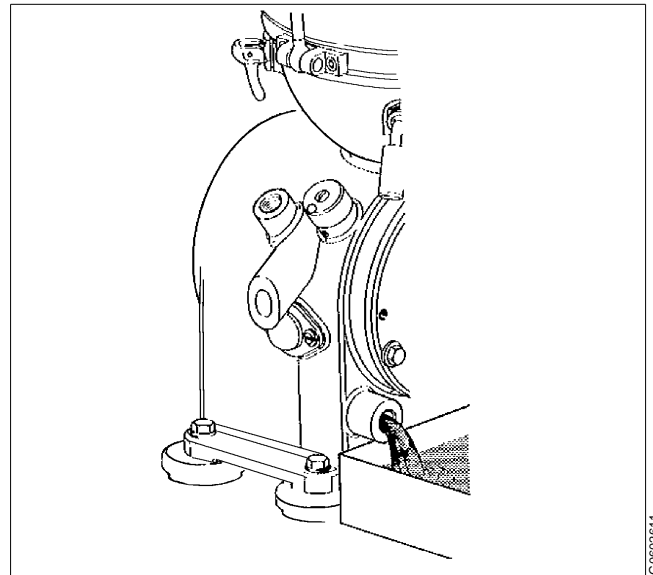

G0602611

Place the separator in such way that makes the oil change easy

8.9.3 Foundations

Specification

- The separator should be installed at floor level, see “8.8.5 Foundation drawing” on page 143.
- The separator must be installed on a strong and rigid foundation to reduce the influence of vibrations from adjacent machinery.
- The foundation should be provided with a cofferdam.

Fit the separator frame on the foundation as follows:

1. Place the separator frame without cushions in position.
2. Check that the bolts do not press against the edges of the holes, otherwise the elasticity of the mounting of the separator frame will be impeded.
3. Check that the separator frame is horizontal and that all feet rest on the foundation.
4. Fit height adjusting washers required.
5. Lift the separator frame, fit the vibration dampers, lower and check that the bolts do not press against the edges of the holes.
6. Tighten nut with 16 Nm. Hold firmly and secure with the lock nut. Repeat for the other frame feet.

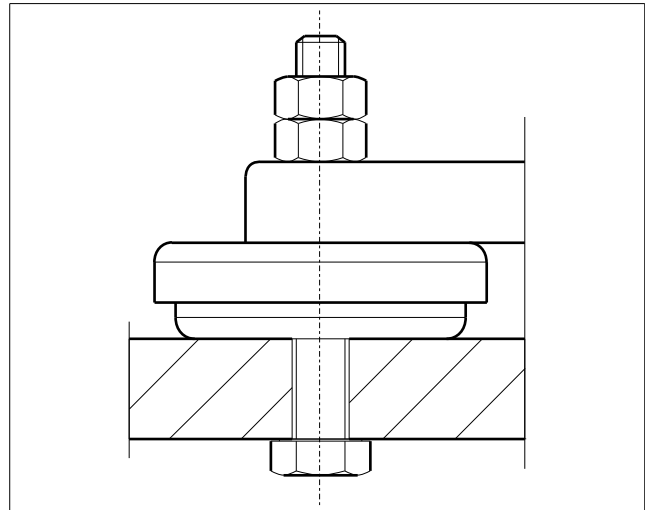

Foundation foot

G0605311

Reader's Comment Form

Dear reader,

It is our ambition to produce as useful and instructive manuals as possible. Should you have any comments (positive or negative) regarding this manual, please note them down and send them to us. You can do this by copying this page and sending it by fax, or you could mail it, or hand it over to your local Alfa Laval representative.

Alfa Laval Separation AB, Separator Manuals, dept. SKL, S-147 80 Tumba, Sweden.
Fax: +46 8 53065029.

Your name:

Company:

Address:

City:

Country:

Product:

MAB 103B-24

Book No.:

1270118-02 V4

Date:

	Yes	No
Is it easy to find what you are looking for by using the table of contents?	<input type="checkbox"/>	<input type="checkbox"/>
Are the chapter and section headings clear and adequate?	<input type="checkbox"/>	<input type="checkbox"/>
Is the information presented in the correct order for your purposes?	<input type="checkbox"/>	<input type="checkbox"/>
Does the information in the manual cover your needs?	<input type="checkbox"/>	<input type="checkbox"/>
Is it easy to understand the instructions in the manual?	<input type="checkbox"/>	<input type="checkbox"/>
Is the terminology sufficiently explained?	<input type="checkbox"/>	<input type="checkbox"/>
Are the illustrations easy to understand?	<input type="checkbox"/>	<input type="checkbox"/>

Your comments:

Order Form

If you wish to order extra copies of this manual, please copy this page and give it to your local Alfa Laval representative, who will advise you of current prices.

Your local Alfa Laval representative will also be able to help you with information regarding any other manuals.

Your name:

Company:

Address:

City:

Country:

Product: MAB 103B-24

Book No.: 1270118-02 V4

Quantity:

Date:

Comments:

Index

B

Bearings	
Assembly of bowl spindle bearings	89
Assembly of horizontal driving device bearings	90
Ball bearing housing damage	62
Maintenance directions	73
Bowl	
Assembly	94
Dismantling	79
Lock ring damage	56
Bowl cleaning	
Procedure	37
Sediment paper	39
Bowl discs	
Cleaning	69
Disc stack pressure	56
Bowl spindle	
Assembly	89
Dismantling	83
Brake	
Checking the brake	103
Function	25
Maximum wear	61
Broken water seal	113

C

Centrifugal separation	16
Clarification	
Oil discharge through water outlet	114
Start procedure	34
Unsatisfactory separation result	114
Clarifier	
Definition	27
Clarifier bowl	
Characteristic parts	22
Exploded view	41
Clarifier disc	
Dismantling	81
Cleaning	
Bowl cleaning	37
Bowl discs	69
External cleaning	66
Fuel oil separators	67
Lube oil separators	67
Time intervals	37
Connection list	124
Connection list, for heater	127

Corrosion	
Check points	52
Maintenance logs	46
Oiling of parts	68
Shutdowns	75
Coupling	
Exchange of friction elements	87
Friction pads	61
General maintenance	74
Cover interlocking switch (option)	26
Cracks	
Check points	55
Maintenance logs	46

D

Daily checks	47
Density of feed	117
Disc stack pressure	56
Drawings	
Basic size drawing	122
Basic size drawing, for heater	125
Foundation drawing	143
MAB 103B, exploded view	140
Machine plates and safety labels	148
Pump	142

E

Electric motor	146
Emergency stop	36, 128
Erosion	
Check points	54
Maintenance logs	46
Excessive vibration during normal running	108
Excessive vibration during starting sequence	108

F

Foundation	156
Frame feet	
Vibration dampers exchange	104
Friction coupling	
Function	24

G		N	
<hr/>		<hr/>	
Gear		Noise	
Number of teeth	117	Sound power level	118
Wear of gear teeth	63	Sound pressure level	118
Gravity disc		O	
Dismantling	81	<hr/>	
Selection	30	Oil	
H		Before first start	30
<hr/>		Oil change intervals	44
Horizontal driving device		Oil change procedure	70
Assembly	90	Sight glass	26
Dismantling	87	Oil discharge through water outlet	113
I		Outgoing water contaminated by oil	112
<hr/>		P	
Installation		<hr/>	
Checkpoints	30	Power consumption	117
Planning of installation	153	Power transmission	
Interface		Description	24
Definition	27	Process capacity	116
Interface description	128	Pump	
L		Axial play	98
<hr/>		Bushings	97
Lifting instruction	76, 144	Dismantling	97
Liquid flows through bowl casing drain	111	Function	25
Lock ring		Impeller shaft	97
Wear and damage	56	Lipring seals	97
Lubricants	131	Shear pin coupling	97
Lubricating oil volume	118	Wearing seals	97
Lubrication		Pump capacity	118
Oil change procedure	70	Pumps	
Oil filling procedure	102	Checkpoints	97
M		Purification	
<hr/>		Broken water seal	113
Main parts	19	Definition	27
Maintenance		Outgoing water contaminated by oil	112
Maintenance intervals	44	Start procedure	34
Maintenance procedure	45	Unsatisfactory separation result	112
Service kits	46	Purifier bowl	
Major service	49	Characteristic parts	20
Materials	118	Exploded view	40
Maximum running time without flow	117	Gravity disc	20
Metal surfaces		R	
Corrosion	52	<hr/>	
Cracks	55	Ready for start	128
Erosion	54	Revolution counter	
Gear teeth wear	63	Function	26
Motor		Speed	117
Coupling disc	60	Rotor	
Motor cleaning	66	Assembly	94
Motor current during start	33	Dismantling	79
		Running-up procedure	32

S

Safety Instructions	9
Separated sludge	
Cleaning the bowl	37
Separation	
Clarification	22
Optimum separation	21
Purification	20
Temperature	17
Viscosity	17
Separator	
Stopping time	117
Separator does not start.	106
Separator exploded view	23
Separator vibration level	118
Service kits	46
Shear pin coupling	98
Shutdowns	75
Sludge and water space volume	118
Smell	109
Speed	117
Speed too low	110
Start	32
Checkpoints	31
Clarification start procedure	34
Purification start procedure	34
Starting power too high	107
Starting power too low	107
Starting time	117
Start-up time too long	106
Stopping procedure	35
Stopping time too long	110
Storage	151

T

Throughput	
Definition	27
Trouble tracing	106

U

Unsatisfactory separation result	112
----------------------------------	-----

V

Vertical driving device	
Assembly	89
Dismantling	83
Vibration	
Critical speed	32
Spindle wobble	58
Vibration checking	72
Vibration level	118

W

Warning signs	13
Water in oil sump	110
Weight	118
Worm gear	
Function	24
Worm wheel	
Assembly	91